

ORDINANCE 1 - 95

AN ORDINANCE ADOPTING AND CONFIRMING SEPTIC SYSTEM REGULATIONS FOR MADISON COUNTY AND IMPOSING FEES.

WHEREAS Madison County is mandated by State law and by prudence to require septic system regulations, and

WHEREAS septic system regulations were first adopted on October 15, 1991 and have been in continuous use and force ever since, and

WHEREAS action was taken to revise the fee schedule in April of 1993, and

WHEREAS it is desirable to make a complete record of County action and also to provide an opportunity for public participation when fees are involved,

NOW THEREFORE BE IT ORDAINED:

1. Madison County septic system regulations are hereby and shall be adopted as provided in the attached stapled booklet Exhibit "A".

2. Fees shall be imposed as provided in Appendix "B" attached as Exhibit "B" which schedule of fees shall be substituted for those fees designated in Appendix "B" in the stapled booklet which is itself Exhibit "A".

PASSED AND APPROVED BY THE BOARD OF COUNTY COMMISSIONERS OF MADISON COUNTY, MONTANA, ON FIRST READING THIS 13 DAY OF MARCH 1995.



JOHN ALLHANDS, CHAIRMAN

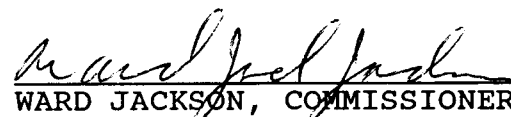

WARD JACKSON, COMMISSIONER

PASSED AND APPROVED BY THE BOARD OF COUNTY COMMISSIONERS FOR
MADISON COUNTY, MONTANA, SECOND READING THIS 3 DAY OF APRIL,
1995.



JOHN ALLHANDS, CHAIRMAN



WARD JACKSON, COMMISSIONER

Exhibit "A"

**MADISON COUNTY
SEPTIC SYSTEM
REGULATIONS**

TABLE OF CONTENTS

Section 1	Purpose of Regulations.....	1
Section 2	Authority and Scope of Regulations.....	2
Section 3	Effective Date and Review Procedures.....	3
Section 4	Definitions.....	3
Section 5	Applications for Permits.....	6
Section 6	Review of Application.....	9
Section 7	Issuances of Permits.....	9
Section 8	Denial of Permits.....	10
Section 9	Variance and Appeals.....	11
Section 10	Inspections of Wastewater Treatment Systems.....	12
Section 11	Operation of Wastewater Treatment Systems.....	13
Section 12	Installer Licensure.....	13
Section 13	Enforcement Provisions.....	15
Section 14	Severability and Conflicts.....	15
Section 15	Minimum Requirements for Wastewater Treatment Systems.....	16
Section 16	Sewer Design.....	17
Section 17	Primary Treatment.....	18
Section 18	Secondary Treatment.....	20
Section 19	Conventional Systems.....	22
Section 20	Standard Alternative Systems.....	25
Section 21	Experimental Alternative Systems.....	30
Section 22	Multi-user Systems.....	44
Section 23	Restricted Systems.....	44
Section 24	Innovative Alternative Systems.....	47
Section 25	Replacement Systems.....	48

SECTION 1
Purpose of Regulations

- 1.1 The Madison County Board of Health recognized the importance of proper treatment and disposal of wastewater. Diseases such as dysentery, infectious hepatitis, typhoid, paratyphoid, and various types of diarrheal infections are transmitted from one person to another through fecal contamination of food and water. Improper treatment of wastewater plays an important role in the transmission of these diseases. For this reason every effort should be made to prevent such hazards. Important to the prevention of disease is the proper treatment as well as the disposal of wastewater.
- 1.2 Safe treatment and disposal of all wastewater is necessary to protect public health and the environment, and to prevent the occurrences of public health nuisances. To insure satisfactory results, wastewater must be treated and disposed of so that:
 - 1.21 It will not contaminate any existing or future drinking water supply.
 - 1.22 It will not pollute or present the potential to contaminate any surface or ground water.
 - 1.23 It is not accessible to insects, rodents, or other possible carriers of disease which may come into contact with food or drinking water.
 - 1.24 It is not a health hazard by being accessible to children.
 - 1.25 It will not give rise to a nuisance due to odor or unsightly appearance.
 - 1.26 It will not violate other laws or regulations governing water pollution or wastewater disposal.
- 1.3 It is with this criteria in mind that the Madison County Board of Health has developed the following regulations. The basic principles and standards on the siting, design, construction, installation and maintenance of wastewater treatment systems are adopted to insure the proper treatment and disposal of wastewater and to alleviate potential public health hazards.

SECTION 2
Authority and Scope of Regulations

- 2.1 This Regulation has been written pursuant to Title 50-2-116-Powers and Duties of Local Boards- (1) (i) "adopt necessary regulations that are no less stringent than state standards for the control and disposal of sewage from private and public buildings that is not regulated by Title 75, chapter 6, or Title 76, chapter 4. The regulations must describe standards for granting variances from the minimum requirements that are identical to standards promulgated by the Board of Health and Environmental Sciences and must provide for appeal of variance decisions to the Department as required by 75-5-305" and (2) (j) "adopt necessary fees to administer regulations for the control and disposal of sewage from private and public (fees must be deposited with the County Treasurer);
- 2.2 This Regulation covers ALL types of "Individual Wastewater Treatment Systems" and Multi-user Wastewaste Treatment Systems", as defined herein, in Madison County.
- 2.3 All structures, regularly occupied by people, producing wastewater shall utilize either a permitted individual wastewater treatment system or multi-user wastewater treatment system with the following exceptions:
- 2.31 The wastewater treatment system was installed prior to October 15, 1991, the effective date of the first county regulations governing septic systems. Such systems must meet the requirements in Section 1.2 of this Regulation.
- 2.32 The wastewater treatment system installed was not governed by the septic system regulations in effect at the time of installation.
- 2.33 The wastewater treatment system being utilized is a public sewage disposal system approved by the Montana Department of Health and Environmental Sciences.
- 2.4 The permit system established through this Regulation governs only the installation and operation of wastewater treatment systems. This permit is not to be construed as a building permit or any other permits that may be required by other agencies or offices to erect a structure in Madison County.
- 2.5 The permit established the minimum criteria for the wastewater treatment standards adopted in Madison County. The county does not design the wastewater treatment systems. The requirements set forth in the permit do not in any way bind or obligate the county to guarantee the operation of any system.
- 2.6 The Madison County Health Department may require the applicant, through the permitting process, to verify compliance or the ability to comply with other agencies', districts', or other governmental entities', bylaws, ordinances, zoning laws, rules, or regulations, when deemed pertinent by the Department, to protect the applicants' interest.

SECTION 3
Effective Date and Review Procedures

- 3.1 All provisions established under this Regulation shall become effective as of April 19, 1993.
- 3.2 The Board may, as deemed necessary, conduct a detailed review of this Regulation. Revisions shall be made as needed to insure proper administration and to allow for improved methods of wastewater treatment.

SECTION 4
Definitions

- 4.01 "Abandoned" Shall mean any wastewater treatment system whose structure it serves has changed from the structure described with the permit. If a wastewater treatment system was installed prior to October 15, 1991, said system shall be deemed abandoned if the structure it serves is changed or substantially remodeled. Wastewater treatment systems serving mobile home parks shall not be deemed abandoned with a normal turnover of units.
- 4.02 "Absorption System" shall mean a leaching field of trenches or another system that provides treatment of wastewater by means of absorption into the subsurface soil.
- 4.03 "Applicant" shall mean any person, institution, public or private corporation, partnership, or other entity that submits an application for a permit to construct, repair, replace, or alter a wastewater treatment system.
- 4.04 "Alter" shall mean physically changing a wastewater treatment system by adding to or subtracting from said system, increasing the flow into a system above said systems's design flow, or hooking into an abandoned system. Increasing flow shall include adding bedrooms to a residence.
- 4.05 "Bedrock" shall mean a consolidated rock formation of impervious material that may exhibit a jointed, fractured, or cohesive structure. It shall also include the above material in a decomposing state.
- 4.06 "Board" shall mean the Madison County Board of Health.
- 4.07 "Certificate of Subdivision Plat Approval" shall mean the statement produced by the Montana Department of Health and Environmental Sciences approving a reviewed parcel for structures requiring a water supply and sewer.
- 4.08 "Construct" shall mean the installation of or excavation for any part of a wastewater treatment system.

- 4.09 "Conventional System" shall mean a wastewater treatment system composed of a septic tank and an absorption field consisting of standard absorption trenches.
- 4.10 "Department" shall mean the Madison County Health Department.
- 4.11 "Design Flow" shall mean the estimated volume in U.S. gallons of wastewater to enter a proposed system. Design flow is used to determine system size and design.
- 4.12 "Distribution Box" shall mean a watertight receptacle which collected effluent and distributes the effluent to an absorption system.
- 4.13 "Dosing" shall mean a high rate of periodic discharge to the absorption system.
- 4.14 "Drainrock" shall mean clean, washed gravel or crushed stone ranging in size from 3/4 to 2 1/2 inches.
- 4.15 "Effluent" shall mean the discharge of liquid waste.
- 4.16 "Experimental Alternative System" shall include all the systems described in Section 21 of this regulation.
- 4.17 "Fill" shall mean soil materials that have been displaced from their original location. Fill material that has set for five years or more shall be deemed natural soil.
- 4.18 "Floodplain shall mean the area adjoining the watercourse or drainway which would be covered by the floodwater of a flood of 100- year frequency except for sheetflood areas that receive less than one (1) foot of water per occurrence and are considered "Zone B" by the Federal Emergency Management Agency.
- 4.19 "Flow" shall mean the actual volume in U.S. gallons of wastewater entering a system per day.
- 4.20 "Grey Water" shall mean any wastewater other than toilet wastes and includes, but is not limited to, shower and bath wastes, kitchen wastewater, and laundry wastes.
- 4.21 "Health Officer" shall mean the legally established authority as designated by the Madison County Board of Health.
- 4.22 "High Groundwater" shall mean the vertical distance from the natural ground surface to the upper surface of groundwater as observed as a free water surface in an unlined hole during the time of year when the groundwater is the highest.
- 4.23 "Holding Tank" shall mean a watertight receptacle for the retention of wastewater where an effluent is not generated.

- 4.24 "Individual Wastewater Treatment Systems" shall mean a system designed to serve one single family dwelling or any structure not utilized for "multi-user" purposes.
- 4.25 "Licensed Installer" shall mean an individual that holds a current license, issued by the Department, to construct, repair, replace, or alter a wastewater treatment system under the terms of this regulation.
- 4.26 "Limiting Layer" shall mean any layer of soil with a stabilized percolation rate slower than 60 min/inch.
- 4.27 "Monitoring Wells" shall mean a ten (10) foot piece of four (4) inch perforated PVC pipe installed vertically in a hole excavated to eight (8) feet. The excavation shall be backfilled around the pipe and slightly mounded to excluded surface runoff.
- 4.28 "Multi-user Wastewater Treatment System" shall mean all systems except "Individual Wastewater Treatment Systems", and "Public Sewage Disposal Systems" as defined herein.
- 4.29 "Nuisance" shall mean anything which is indecent or offensive to the senses.
- 4.30 "Owner" shall mean the person who is shown to be the legal title holder of a particular parcel of land.
- 4.31 "Percolation Test" shall mean a soil test at the depth of a proposed absorption system to determine the water absorption capability of the soil, the results of which are normally expressed as a rate at which one (1) inch of water is absorbed. The standard procedure can be found in Appendix A of this Regulation.
- 4.32 "Permit" shall mean a written authorization issued by the Department allowing construction, repair, replacement, or alteration of a wastewater treatment system under this Regulation.
- 4.33 "Primary Treatment" shall mean the process of removing grease and settleable solids from the wastewater. This is typically done with a septic tank.
- 4.34 "Public Sewage Disposal System" shall mean a sewage disposal system that serves ten (10) or more families or twenty-five (25) or more persons for at least sixty (60) days out of the calendar year. Public sewage disposal systems shall be reviewed and approved by the Montana Department of Health and Environmental Sciences.
- 4.35 "Repair" shall mean repairing or replacing any component of a wastewater treatment system due to a physical failure of that component. The Department shall determine if the repair is so minor as to not require a permit. The Department may require any component to be upgraded during the repair if said component is likely to fail or cause failure.

- 4.36 "Secondary Treatment" shall mean process by which the effluent is further treated to remove biological contaminants and reduce nutrient levels. This is typically done with a absorption system.
- 4.37 "Septic Tank" shall mean a watertight accessible covered receptacle designed and constructed to receive wastewater from a structure(s) and provides primary treatment.
- 4.38 "Sewer" shall mean the PVC pipe connecting the house sewer to the septic tank and connecting the septic tank to the secondary treatment system.
- 4.39 "Slope shall mean the quotient of the vertical rise divided by the horizontal run and is expressed as a percentage.
- 4.40 "Soil Profile" shall mean a detailed description of the soil strata to a depth of at least seven (7) feet. The description can be expressed using the U.S. Department of Agriculture's Soil Classification System or the United Soil Classification System. The description of the soil shall be provided by a person competent in soil analysis.
- 4.41 "Surface Water" shall mean any body of water or watercourse, including lakes, ponds, rivers, creeks, streams, irrigation ditches, seeps, and swamps.
- 4.42 "Surface Water" shall mean a combination of liquid wastes that may include usual household chemical, domestic wastes, human excreta, and animal and vegetable matter in suspension or solution which are discharged from a dwelling, building or other establishment. Within the scope of this definition wastewater shall include grey water.
- 4.43 "Wastewater Treatment System" shall mean a system for sanitary collection, transportation, treatment and disposal of wastewater, operated in accordance with State and Local Board of Health Regulations.

SECTION 5 Applications for Permits

- 5.1 It shall be unlawful for any person to construct a new wastewater treatment system or to repair, replace or alter an existing system within Madison County unless that person holds a valid permit issued by the Department for specific construction, repair, replacement and alteration proposed. Systems installed prior to October 15, 1991, the effective date of the first county regulations governing septic systems, must meet the requirements in Section 1.2 of this Regulation.
- 5.2 Application for permits shall be made to the Department. Permits shall be issued upon compliance by the applicant with the provisions of this Regulation. Application for permits shall be made in writing on forms supplied by the Department, shall be signed by the applicant, and shall include, but not be limited to, the following:

- 5.21 Name and address of applicant.
- 5.22 Legal description (Section, Township, Range) subdivision (phase, block, lot) if applicable and a copy of the authorized address assignment from the Madison County Road Department of the property for which the permit is being applied for.
- 5.23 Parcel size.
- 5.24 The number, location, type and size of structures, both existing and proposed, to be connected to the system.
 - a. Number of bedrooms to be served by the system for residences, or,
 - b. Estimated volume of wastewater produced and how this volume was determined for non-residences.
- 5.25 A site plan showing the following.
 - a. Shape and size of the parcel.
 - b. Proximity to all water supplied, open bodies of water and floodplain.
 - c. Design of the wastewater treatment system.
 - d. Area of 100% replacement absorption system.
 - e. Location of any drainage ways, if present.
 - f. Location of house site, driveways, out-buildings, etc.
 - g. North point.
- 5.26 Name of licensed installer installing the wastewater treatment system.
- 5.27 A permit fee in accordance with the Schedule of Fees found in Appendix B of this Regulation.
- 5.28 To protect the applicants interest, proof of compliance or the ability to comply with other agencies', districts', or other governmental entities' bylaws, ordinances, zoning laws, rules or regulations, when deemed pertinent by the Department, to protect the applicants' interest.
- 5.3 If the property proposed for the water treatment system construction, repair, replacement, or alteration has not been reviewed and does not have a Certificate of Subdivision Plat approval, the Department shall be provided with, but not limited to, the following additional information to determine the suitability of the property for the wastewater treatment system construction, repair, replacement, or alteration before a permit is issued:

- 5.31 Name and qualifications of the site evaluator. The site evaluation may be performed by a person approved by the Department. The site evaluator must have a knowledge of soils and how they relate to the design and function of wastewater treatment systems. Engineers, soil scientists, licensed installers, and Registered Sanitarians are examples of qualified site evaluators. The applicant may request the Department to perform the site evaluation. A site evaluation fee will be assessed in accordance with the Schedule of Fees found in Appendix B of this Regulation.
- 5.32 A soil profile description from a pit excavated to a minimum depth of 7 feet. Copies of a Soil Conservation Services (SCS) Survey may be submitted in lieu of a test hole if such data demonstrates suitable soil conditions for a sewage treatment system. The following factors must be included in any soils evaluation.
- a. Thickness of layers or horizons of the soil profile.
 - b. Texture (USDA Soils Classification System) and structure of horizons.
 - c. General color and color variation (mottling)
 - d. Depth to water, if observed.
 - e. Depth to bedrock or other limiting layer (perc rate $\times 60$ min/inch), if observed.
 - f. Other prominent features that would have a bearing on a site's compatibility for use as a sewage treatment site (i.e. stoniness, root depth, etc.).
 - g. The location of the soil pit on the site plan.
- 5.33 The depth to the seasonal high groundwater table. Explain how this determination was made and why it is thought to be representative of the seasonal high level. For a marginal site, monitoring wells shall be installed by the applicant and monitored through the high groundwater period. Monitoring shall be performed by a person approved by the Department or by the Department itself for a fee assessed in accordance with the Schedule of Fees in Appendix B. of this Regulation. A report from a qualified professional such as a soil scientist, hydrogeologist, Registered Sanitarian, or an engineer with knowledge of soils may be substituted for actual monitoring if the professional can confidently estimate the seasonal high level.
- 5.34 Results of two percolation tests. The test shall be conducted in accordance with Appendix A of this Regulation. The tests shall be evenly spaced across the proposed primary absorption system and their location shown on the site plan. If the percolation tests

are done by a person other than the site evaluator, the site evaluator must sign off the results attesting to their accuracy.

- 5.35 Type and percent of land slope across the proposed absorption system. Describe the type of slope (concave, convex, or plane) for the purposed primary and replacement drainfield locations. Determine the percent (vertical rise/horizontal run) and direction of the slope.
- 5.36 Evaluation of the potential for flooding or accumulation of surface water.

SECTION 6 Review of Application

- 6.1 The completed application form shall be returned to the Department with ALL required information and fees.
- 6.2 The Department shall review the application for completeness and to determine compliance with the site requirements as set forth in this Regulation.
 - 6.21 The Department shall respond within ten (10) working days from the date the completed application was filed.
 - 6.22 The Department shall respond within thirty (30) calendar days for multi-user wastewater treatment systems, public subsurface wastewater treatment systems, or those systems requiring engineering review.
- 6.3 Response from the Department shall be in the form of a valid permit for an approved application or a written denial detailing the deficiencies of an unapproved application.

SECTION 7 Issuance of Permits

- 7.1 A permit to construct, repair, replace or alter a wastewater treatment system shall be issued by the Department upon finding an application complete and in compliance with the site requirements set forth in this Regulation.
- 7.2 The Department may place specific conditions on the permit to facilitate compliance with any provision of this Regulation.
- 7.3 Unapproved changes in plans or specifications after the permit has been issued or any falsification or significant error in data or information submitted by an applicant shall invalidate the permit.
- 7.4 Construction, repair, replacement, or alteration of a wastewater treatment system may begin upon issuance of a permit for the specified construction, repair, replacement, or alteration.

- 7.5 If a wastewater treatment system for which a permit has been issued has not been installed, inspected and approved within 12 months for an individual system or 24 months for multi-user systems after issuance of the permit, the permit shall be voided by the Department.
- 7.6 A permit may be extended for an additional 12 months if the Department is notified of the request for the continuation prior to expiration of the permit and all requirements which exist at the time of continuation can be met. A continuation fee in accordance with the Schedule of Fees found in Appendix B. of this Regulation shall be remitted.
- 7.7 There will be no reimbursement of fees received for the issuance of a permit if said permit is voided or invalidated.
- 7.8 All information submitted with the application becomes the property of the Department and will not be returned.

SECTION 8 Denial of Permits

- 8.1 The Department may disapprove an application for the construction, repair, replacement or alteration of wastewater treatment system if the Department determines that:
 - 8.11 The proposed wastewater treatment system will not comply with the requirements or specifications of this regulation or,
 - 8.12 The applicant has failed to supply all data necessary to make a determination as to whether or not the proposed wastewater treatment system complies with the requirements or specifications of this Regulation and has failed to provide such information within thirty (30) days after a written notice for such additional information has been made by the Department, or,
 - 8.13 The applicant has failed to pay the required fees and has failed to make such payment within thirty (30) days after notice of non-payment has been mailed to the applicant by the Department.
- 8.2 If a parcel of land is presently being reviewed under the Sanitation in Subdivision Act, no permit can be issued for any structure on that parcel of land until the review of said subdivision is completed and the subdivision approved. If the subdivision is reviewed and disapproved and the owner proposes building a structure on a portion of the property that can comply with this Regulation and it does not conflict with any provision of the disapproval, application for a sewage treatment system permit can be made as outlined in Section 5.
- 8.3 A permit may be denied if it is found that such installation is in conflict with the requirements of the Sanitation in Subdivision Act or its regulations.

- 8.4 A permit may be denied if it is found that any provision of a Certificate of Subdivision Plat Approval has been violated or there is departure from any criteria set forth in the approved plans and specifications of said subdivision.
- 8.5 Permit fees submitted by the applicant shall be returned to the applicant with the denial notice. All information submitted with the application becomes the property of the Department and will not be returned.

SECTION 9 Variances and Appeals

- 9.1 An applicant or any affected person may request a variance from any particular requirement of this Regulation by filing a petition with the Health Officer. The petition shall contain the following information.
- 9.11 Evidence that the system that would be allowed by the variance is unlikely to cause pollution of state waters.
- 9.12 Evidence that the granting of the variance will protect the quality and potability of water for public water supplies and domestic uses, and will protect the quality of water for the other beneficial uses.
- 9.13 Evidence that granting of the variance will not adversely affect public health, safety, and welfare.
- 9.14 A summary explanation of the project or development and the reason a variance is being sought.
- 9.15 Evidence that the granting of the variance will not adversely affect public health, safety, and welfare.
- 9.2 The Health Officer shall review the petition and relevant information within thirty (30) days upon receipt and either grant, grant with conditions, or deny the requested variance. Reasons for any decision will be provided in writing to the person seeking the variance.
- 9.3 The Health Officer's decision may be appealed to the Madison County Board of Health. The appeal will be presented at the next regularly scheduled meeting of the Board provided that such request is received ten (10) written days prior to the scheduled meeting date. At this meeting, the appellant may appear in person, be represented by another person, or may appeal to the Board in writing. The Board shall respond to the appellant in writing stating its decision and the reasons therefore within thirty (30) days after hearing and/or reviewing the appeal. The decision shall be to grant, grant with conditions, or deny the variance.

- 9.4 The appellant, upon exhausting the appeals process listed in this Section may, under Section 75-5-305, MCA, take the appeal to the Montana Department of Health and Environmental Sciences.

SECTION 10

Inspections of Wastewater Treatment Systems

- 10.1 All wastewater treatment systems governed by these regulations shall be inspected by the Department prior to backfilling all or any portion of said system unless specific permission has been granted by the Department.
- 10.2 The applicant or installer shall request an inspection from the Department not less than eight (8) working hours prior to completion. Inspections shall be conducted by the Department during normal working hours.
- 10.3 The issuance of a permit to construct, repair, replace, or alter a wastewater treatment system establishes landowner consent which allows the Department to enter the property for the purpose of making inspections to determine compliance with this Regulation and the specification of the permit.
- 10.4 If, upon final inspection of the wastewater treatment system, the Department finds the system in compliance with the plans and specifications filed with the permit and this Regulation, the Department shall issue final approval for the completed system.
- 10.5 Final approval for engineered systems will be issued after the design engineer furnishes an as-built drawing of the system and written certification that the system was installed in accordance with the approved design.
- 10.6 If, upon final inspection of the wastewater treatment system, the Department finds the system deviates significantly from the plans and specifications filed with the permit or is not in full compliance with this Regulation, the Department shall withhold final approval. The Department shall clearly mark the system with surveyors tape and shall notify the applicant or owner immediately of the deficiencies and require that corrective action be taken. The deficiencies shall be corrected within fifteen (15) days of notification, unless a longer compliance schedule is approved by the Department.
- 10.7 A reinspection shall be made upon the request of the applicant or installer, as specified in this Section, to ensure the deficiencies have been corrected and the system is in compliance with the plans and specifications filed with the permit and this Regulation. A reinspection fee in accordance with the Schedule of Fees found in Appendix B of this Regulation shall be submitted before the Department issues final approval.

- 10.8 Inspections of wastewater treatment systems by the Department as required by this Regulation are performed strictly for the purpose of determining compliance with this Regulation. Inspections are not conducted for the purpose of analyzing or insuring workmanship. Final approval of the wastewater treatment system shall not be construed as a guarantee to the life expectancy or operation of the system.

SECTION 11

Operation of Wastewater Treatment Systems

- 11.1 The property owner shall be responsible for the proper operation, maintenance, and cleaning of the system and/or abatement of any nuisance arising from its failure.
- 11.2 The Department may require the owner of a wastewater treatment system to maintain and submit records of inspection, maintenance, cleaning and testing performed on the system to the Department.
- 11.3 It shall be unlawful for any person utilizing a wastewater treatment system to dispose of hazardous chemicals such as, but not limited to, gasoline, oil, paint, paint thinner, antifreeze, pesticides, solvents, and oven cleaners into the system.
- 11.4 The Department is hereby empowered and authorized to enter upon private property for the purpose of inspecting a wastewater treatment system or to determine compliance with this Regulation. The owner or occupant of property having a wastewater treatment system shall give the Department free access to the property for such inspection, including the taking of effluent samples. This Section does not, however, authorize the Department to enter any private residence without otherwise complying with the law.

SECTION 12

Installer Licensure

- 12.1 It shall be unlawful for any person, except as delineated in this Section, to construct, repair, replace, or alter a wastewater treatment system within Madison County unless that person holds a valid Madison County Wastewater Treatment System Installer's License. The licensed installer must be present at the site for the duration of the work being performed on the system. A homeowner constructing, repairing, replacing or altering a wastewater treatment system for his/her own property is exempt from this requirement. Builders who may own several parcels of land and who build structures on these parcels for sale, rent, or lease and not for the purpose of their residing in said structures, shall not be considered a "homeowner" and are not exempt from this requirement.
- 12.2 All first time applications for installer licenses shall be made to the Department who may grant the license upon completion of the following:

- 12.21 Submitting a completed license application which contains the name, address, and telephone number of the applicant.
- 12.22 Successful completion of the licensing examination which will be administered by the Department.
- 12.23 Receipt of the license fee in accordance with the Schedule of Fees found in Appendix B of this Regulation.
- 12.3 All applications for license renewal shall contain all the elements of a first time application except the examination requirement may be waived if the applicant has demonstrated knowledge of good wastewater system design and installation in the year immediately preceding the application.
- 12.4 Installer licenses shall be valid from January through December 31, for the year stated on the license unless revoked, and shall be renewable by March 1 of the following year. Licenses are not transferable.
- 12.5 Installer licenses may be denied for any of the following reasons:
 - 12.51 Having constructed, repaired, replaced, or altered a wastewater treatment system without a valid permit, and/or,
 - 12.52 Having his/her installer license revoked within twelve (12) months preceding the application and/or
 - 12.53 Failure to meet the terms of License Application.
- 12.6 The Department shall notify the license installer of the revocation and the grounds of the decision by personal service or certified mail.
- 12.7 Installer licenses are the property of the Department and may be revoked by the Health Officer at any time for the following reasons:
 - 12.71 Construction, repair, replacement, or alteration of a wastewater treatment system prior to the issuance of a permit, and/or
 - 12.72 Failure to gain approval for a wastewater treatment system construction, repair, replacement, or alteration, and/or
 - 12.73 Having provided false evidence or information to obtain a permit or gain approval of a wastewater treatment system construction, repair, replacement or alteration.
- 12.8 The licensed installer may appeal the revocation to the Madison County Board of Health under the procedures specified in Section 9.3. The decision of the Board shall be determined as final.
- 12.9 The term of revocation will be for one calendar year from the date of the revocation. Relicensure shall be permitted only after completion of the requirements set forth in Section 12.2.

SECTION 13

Enforcement Provisions

- 13.1 Cease and Desist Order - The Department may issue a written order to any person or persons to cease and desist from the use of any system which is found by the Department not to be functioning in compliance with this Regulation. The order shall require that the owner or occupant bring the system into compliance or eliminate the violation within a reasonable period of time not to exceed thirty (30) days, or thereafter cease and desist from the use of the system. Service of such notice shall be by certified mail, return receipt requested, and shall be considered complete on receipt by the Department of the return receipt. The Department shall give the person or persons to whom the order is directed an opportunity for a hearing before the Health Officer within (48) forty-eight hours of the order. Following said hearing, the Health Officer shall affirm, modify or revoke the Cease and desist Order.
- 13.2 Any person who violates any provision of this Regulation shall, upon conviction, be punished by a fine not less than ten (10) dollars and not more than two hundred (200) dollars, for each offense. Each day of violation constitutes a separate offense. The first day of violation shall be the date of the notice of violation.

SECTION 14

Severability and Conflicts

- 14.1 Conflict of Ordinances, Effect on Partial Invalidity: In any case where a provision of this Regulation is found to be in conflict with a provision of any zoning, building, fire, safety, or health ordinance, regulation or code of Madison County, or any municipality with Madison County existing on the effective date of this regulation, the provision which, in the opinion of the Department, establishes the higher standard for the protection of the health and safety of the people, shall prevail.
- 14.2 If any section, subsection, paragraph, sentence, clause, or phrase of the Regulation should be declared invalid for any reason whatsoever, such decision shall not affect the remaining portion of this Regulation which shall remain in full force and effect; and to this end, the provisions of this regulation are hereby declared to be severable.

SECTION 15

Minimum Requirements for Wastewater Treatment Systems

15.1 General

- 15.11 Wastewater treatment systems shall not violate the requirements of Section 1.2.

15.12 The wastewater treatment system shall consist of a sewer line from a point two (2) feet outside the foundation wall to the primary treatment device (septic tank) and a sewer line from the primary treatment device (septic tank) to the secondary treatment system (absorption system).

15.13 The wastewater treatment system shall be designed to accept domestic wastes including grey water. Water from roof drains, groundwater, surface runoff, sump pumps, etc., shall not be discharged into a wastewater treatment system and should be purposely diverted away.

15.2 Location

15.21 Location of wastewater treatment systems shall be based on size and shape of the lot, soil types, slope of the land, depth to groundwater, depth to bedrock and other limiting layer, proximity to existing or future water supplies, proximity to existing wastewater treatment systems, proximity to surface water and floodplain, and replacement.

15.22 Minimum separation distances for location of various component parts of the wastewater treatment systems are shown in Table 1.

TABLE 1
Minimum Separation Distances in Feet

<u>From</u>	<u>To</u>	
	Primary Treatment (septic tank) (a)	Secondary Treatment (absorption system)
Wells and Springs	50	100
Suction Lines	50	100
100-Year Floodplain	50	100 (b)
Surface Water	50	100 (d)
Cisterns	25	50
Slopes in excess of 25%	10	25
Property Lines (e)	10	10
Subsoil Drains	10	10
Water lines	10	10
Absorption System	10	—
Secondary Treatment	10	—
Foundation Walls	5	10
High Groundwater	—	4 (f,g)
Bedrock	—	4 (f)
Limiting Layer	—	4 (f)

- (a) "Septic Tank" shall include pumping chambers where applicable.
 - (b) This requirement may be waived if the applicant submits evidence that the average yearly high water mark is 50 feet from the septic tank and 100 feet from the absorption system and the absorption system will be 4 feet above the 100-year flood elevation.
 - (c) This distance shall be measured horizontally to the average yearly high water mark.
 - (d) This separation distance may be reduced to 50 feet if the surface water is an irrigation ditch and the applicant provides evidence that the groundwater flow at the absorption system site will not enter the irrigation ditch.
 - (e) If a variance is sought from this requirement, written permission must be obtained from the adjoining landowner.
 - (f) The separation to high groundwater, bedrock, or limiting layer shall be measured from the bottom of the drainrock for the absorption system.
 - (g) For the protection of groundwater, the Department may increase this separation distance for soils having excessively fast percolation rates (less than 5 min/inch).
-

15.23 No component of any wastewater treatment system shall be located under driveways, parking areas, or other areas subjected to vehicular traffic except those portions of the system designed to accommodate the above conditions.

15.24 Absorption systems shall not be constructed in soils rated as having severe or very severe limitations for absorption systems by the Soil Conservation Service (SCS) unless that limitation can be overcome or is not present as shown by site evaluation.

15.25 Absorption systems shall not be located in swales or depressions where runoff may flow or accumulate.

15.26 Absorption systems shall not be constructed in unstabilized fill.

SECTION 16
Sewer Design

- 16.1 Sewers shall be made of four (4) inch PVC pipe unless otherwise specified by the Department.
- 16.11 Septic tanks shall have a ten (10) foot section of ASTM D 1785 (schedule 40) PVC pipe entering and exiting the tank. If the sewer length from the dwelling or structure to the septic tank is less than ten (10) feet, then that length of PVC pipe shall be ASTM D 1785.
- 16.12 The piping and fittings of the sewer not specifically addressed in Section 16.11 shall conform to or exceed ASTM D 3034 (schedule 35) specifications.
- 16.13 Sewer pipe shall be joined with elastomeric gaskets or by solvent cement joints.
- 16.14 Transition connections to other materials shall be made by adapter fittings or one piece molded rubber couplings with appropriate bushings for the respective materials.
- 16.2 Sewers shall be watertight.
- 16.3 Sewers shall be laid at least 10 feet horizontally from any existing or proposed water line. The distance shall be measured edge to edge.
- 16.4 If sewers must cross water lines, they shall cross perpendicular to the water line and be laid to provide a minimum vertical distance of eighteen (18) inches between the outside of the water line and the outside of the sewer. This shall be the case where the water line is either above or below the sewer. The crossing shall be arranged so that the sewer joints will be equidistance and as far as possible from the water line joints.
- 16.5 In general, sewers shall be sufficiently deep to prevent freezing. Insulation shall be provided for sewers that cannot be placed at a depth sufficient to prevent freezing.
- 16.6 The sewer line shall be placed at a minimum downward slope of 1/4 inch/foot. Where it is impractical, due to arrangement of buildings or structures to obtain such a slope, the sewer line may have a slope of 1/8 inch/foot if approved by the Department.
- 16.7 The sewer line between the dwelling or structure and the septic tank should be kept to less than twenty five (25) feet. Should a greater distance be necessary, at least one clean-out for every fifty (50) foot length thereafter. If this sewer line has one or more angles greater than 45 degrees, a clean-out shall be installed at each angle greater than 45 degrees.

16.8 If any section of the sewer will be subjected to vehicular traffic, then that section shall be designed to withstand the additional load and present freezing.

SECTION 17
Primary Treatment

17.1 The primary treatment device shall consist of a reinforced concrete septic tank. Cement used in the concrete shall meet requirement of ASTM C 150, Type C or Type 11 with a maximum tricalcium aluminate content of five (5) percent.

17.2 Other devices which can be shown to be acceptable and effective in primary treatment of wastewater and can meet the design specification of concrete septic tank for strength, capacity, and durability may be approved by the Department.

17.3 Septic tanks shall be water tight and designed in accordance with Appendix C.

17.4 Minimum liquid volume requirement for septic tanks are shown in Table 2.

TABLE 2
Minimum Liquid Volume Requirements

<u>Number of Bedrooms</u>	<u>Capacity in Gallons</u>
1	750
2,3,4	1,000
more than 4	1,000 + 250 per additional bedroom over 4

17.5 For structures that cannot be sized according to the number of bedrooms, the septic tank will be sized in accordance to the anticipated maximum daily flow rates.

17.51 For flows of less than 1,500 gallons per day, the tank shall have the capacity of at least 1.5 times the average daily flow.

17.52 For flows of greater than 1,500 gallons per day, the tank shall have a minimum capacity of $V=1,125 + 0.75Q$ where V is the net volume of the tank and Q is the daily wastewater flow in gallons.

17.6 The septic tank shall be installed in a readily accessible location for ease of inspection and maintenance.

17.7 Where the top of the septic tank is located more than eighteen (18) inches below the finished grade of the ground surface, a riser shall be installed to within at least (8) inches of the finished grade.

- 17.8 A sealing material shall be placed around the sewer pipe where it enters and exists the septic tank to form a watertight connection.
- 17.9 Grease traps shall be installed for establishments such as restaurants which produce large quantities of grease.

SECTION 18

Secondary Treatment

- 18.1 ALL wastewater treatment systems, with the exception of some restricted systems (see Section 23 of this Regulation), shall utilize a type of secondary treatment system approved by the Department.
- 18.2 The secondary treatment systems addressed in this Regulation have been put into four classes: Conventional Systems, Standard Alternative Systems, Experimental Alternative Systems, and Restricted Systems. Multi-user and Public Systems, and Replacement Systems use design criteria of these four classes.
- 18.3 Any secondary treatment system not specifically addressed in this Regulation shall be classified as an Innovative Alternative System and shall meet all the requirements of Section 24 of this Regulation.
- 18.4 Most secondary treatment systems utilize soil absorption as the final means of wastewater disposal. Sizing the absorption system is an integral part of wastewater system design. Inadequate absorption area is a major factor in premature failure of systems.
- 18.41 Absorption system size shall be determined by percolation rates and soil type. If the submitted percolation rates vary significantly from the rates typically found in that soil type, the Department may require additional percolation tests and/or size of absorption system solely on soil type.
- 18.42 Minimum absorption system sizes for single family residences and two-family systems are given in Table 3.

TABLE 3
Minimum Required Absorption Area

<u>Soil Texture</u>	<u>Percolation Rate Min/Inch</u>	<u>Absorption Area Square Feet</u>
Gravel, Coarse Sand	< 3	Not suitable for conventional systems
Coarse to Medium Sand	3 to 5	130
Fine Sand, Loamy Sand	6 to 7	140
	8 to 10	160
	11 to 15	190
Sandy Loam, Loam	16 to 20	220
	21 to 25	250
	26 to 30	280
Loam, Porous Silt Loam, Clay Loam	31 to 45	300
	45 to 60	340
Silty Clay Loam, Silty Clay, Clay	> 60	Not suitable for most systems

18.42 Minimum absorption system sizes for structures that cannot be sized according to the number of bedrooms or for absorption systems serving three or more residences are given in Table 4.

- 18.421 Residential Wastewater Flows—Design wastewater flow for single family dwelling units having three bedrooms or less shall be 350 gallons per day. A contribution of 100 gallons per day per bedroom shall be added for each bedroom beyond three in number.
- 18.422 Nonresidential Wastewater Flows - Typical daily flows for a variety of commercial, institutional, and recreational establishments shall be estimated according to Montana Department of Health and Environmental Sciences Circular WQB 4, Chapter 30. The typical flows shall be utilized as minimum design flows. Greater design flows may be required where larger flows are likely to occur such as resort areas.

TABLE 4
Minimum Required Absorption Area

Soil Texture	Percolation Rate Min/Inch	Application Rate gpd/ft squared
Gravel, Coarse Sand	< 3	Not suitable for conventional systems
Coarse to Medium Sand	3 to 5	1.2
Fine Sand, Loamy Sand	6 to 15	0.8
Sandy Loam, Loam	16 to 30	0.6
Sandy Clay Loam, Porous	31 to 45	0.5
Silty Loam, Clay Loam	45 to 60	0.44
Silty Clay Loam, Silty Clay, Clay	> 60	Not suitable for most systems

18.5 An area shall be made available for a 100% replacement of the original system in the event that failure occurs. If this is not possible due to the size or shape of the lot and the lot has not been reviewed and does not have Certificate of Subdivision Plat approval, the applicant may provide the Department with a plan or procedure to correct the system should failure occur.

SECTION 19
Conventional System

19.1 The secondary treatment systems addressed in this Section are various types of absorption systems which have been used extensively and have proven to be effective.

- a. Absorption Fields
- b. Alternating Absorption Fields

19.2 Absorption Fields— Absorption fields are the most commonly used system for secondary treatment of wastewater and shall be considered first before proposing any other secondary treatment system.

19.21 Limitation—Absorption fields shall not be installed when:

- a. Soils have a percolation rate less than three (3) min/inch or greater than sixty (60) min/inch.

- b. Slopes greater than 15%
- c. High groundwater, bedrock, or other limiting layer is within sixty-six (66) inches of the ground surface (Note: This distance may be increased if the soils present will not adequately treat the wastewater due to poor filtering capability).
- d. Absorption area required is greater than 1,000 square feet.

19.22 Design - Absorption fields shall consist of 2 or more absorption trenches.

19.221 Absorption Trench Construction

- a. Absorption trenches shall be twenty-four (24) inches wide and eighteen (18) to thirty-six (36) inches deep. The absorption trench shall have vertical sides and substantially flat bottom.
- b. When the absorption trenches have been excavated, the sides and bottom shall be raked to scarify any smeared soil surfaces.
- c. A minimum of six (6) inches of drainrock shall be placed in the bottom of the absorption trench for bedding.
- d. The distribution line fabricated from four inch diameter ASTM D 2729 perforated sewer pipe shall be carefully centered on top of the bedding.
- e. The distribution line shall be covered within a minimum of two (2) inches of drainrock. The two (2) inch cover shall be level throughout the entire width of the absorption trench.
- f. A permeable cover shall be placed over the drainrock to prevent backfill material from entering the bedding material. Permeable covers include porous plastic filter fabric, one layer of untreated building paper, or a full two (2) inches of compacted straw.
- g. Absorption trenches shall be backfilled after the system has been inspected and approved by the Department. Depth of the backfill material shall be a minimum of twelve (12) inches and a maximum of twenty-four (24) inches. The backfill should be slightly mounded above the surface of the ground to allow for settling.
- h. Absorption trenches shall be excavated at or very near level and the distribution lines shall have a downward slope of 3 to 4 inches per 100 feet.

- i. The maximum length of an absorption trench shall be 100 feet.

19.222 Absorption Field Construction

- a. The sewer line from the septic tank shall run into a baffling device such as a tee or a distribution box before entering the absorption field. Other types of baffling may be approved by the Department if shown to distribute effluent evenly.
- b. If distribution boxes are used, they shall be bedded to prevent settling, they shall be connected to the distribution pipes by a minimum of five (5) feet of schedule 35 PVC pipe, they shall be water tested for equal distribution, and each absorption trench shall be the same length.
- c. If a header is used, to distribute effluent to the absorption trenches, it shall be installed level with an equal number of absorption trenches spaced evenly on both sides of the junction of the sewer pipe.
- d. If a header is used, the absorption trenches should, when possible, be the same length.
- e. The ends of the distribution lines shall be capped or plugged or, when they are at equal elevations, they should be connected.
- f. Where slopes exclude the use of a header, distribution boxes or drop boxes shall be used. If drop boxes are used, the number of trench levels shall not exceed four. Furthermore, the upper two trenches shall contain a minimum of 30% of the absorption area each. Only one drop box shall be permitted for each level of the absorption field.
- g. Absorption trenches shall be separated by a minimum of seven (7) feet as measured from distribution pipe to distribution pipe.
- h. The conventional absorption field shall have an absorption area equal to or greater than that required in Section 15 of this Regulation.
- i. Construction shall not be initiated when the soil moisture is high. (Note: If a fragment of soil from nine (9) inches below the ground surface can easily be shaped into the form of a wire, the soil moisture content is too high for construction purposes).

19.3 Alternating Absorption Fields - This system consists of dividing the absorption field into two separate fields to allow alternate use of individual fields. The "resting" of the fields allows the clogging mat to biodegrade and can extend the life of the absorption system. This type of system is useful in soils with slow percolation rates.

19.31 Limitation - Alternating absorption fields shall not be installed when:

- a. Soils have a percolation rate less than five (5) min/inch or greater than ninety (90) min/inch,
- b. Slopes are greater than 15%,
- c. Bedrock or any other limiting layer is within sixty-six (66) inches of the ground surface,
- d. High groundwater is within ninety (90) inches of the ground surface,
- e. Absorption area required is greater than 1,500 square feet.

19.32 Design- Alternating absorption fields shall meet all the design requirements of Section 19.22 of this Regulation with the following changes:

- a. Alternating absorption fields shall consist of two absorption fields containing equal absorption area. Each field shall contain 75 to 100% of the total required area for a single field depending on the soil types.
- b. Alternating from one field to another shall be accomplished with the use of a diversion valve.
- c. Separation from high groundwater shall be seventy-two (72) inches.
- d. A 100% replacement area will still be required unless this is waived by the Department in accordance with Section 18.5.

19.33 Operation - A record of absorption field alternating shall be kept by the owner. Alterating shall be on an annual basis.

SECTION 20

Standard Alternative Systems

20.1 The secondary treatment systems addressed in this Section are variations of the absorption field. Standard alternative systems are designed to overcome some of the limitations of a absorption fields. A detailed design of the system will be required before the Department will issue a permit. Design criteria shall conform to the minimum design criteria set forth in this Regulation.

- a. Shallow Capped Absorption Fields
- b. Waste Segregation Systems
- c. Deep Absorption Fields
- d. Sand Lined Absorption Fields
- e. Cut Systems
- f. Dosed Systems
- g. Sloped Absorption Fields

20.2 Shallow Capped Absorption Field - This system is very similar to the conventional absorption field with the exception of absorption trench depth. The main purposes of shallow capped absorption fields are to maintain a four (4) foot separation between high groundwater, bedrock or limiting layer and/or to increase the separation distance to add to subsurface treatment in porous soils.

20.21 Limitation - Shallow capped absorption fields shall not be installed when:

- a. Soils have a percolation rate less than five (5) min/inch unless the shallow capped absorption field is used in conjunction with certain experimental alternative systems described in Section 21 of this Regulation and conditions are set by the Department are met, or greater than sixty (60) min/inch.
- b. Slopes are greater than 15%;
- c. High groundwater, bedrock, or any other limiting layer is within sixty (60) inches of the ground surface.

20.22 Design - Shallow capped absorption fields shall meet all the design requirements of Section 9.22 of this Regulation with the following changes:

- a. Absorption trenches shall be twelve (12) to eighteen (18) inches deep.
- b. The backfill shall be tapered from the edge of the absorption trench wall with a 3 horizontal to 1 vertical or lesser slope.

20.3 Waste Segregation System - This system consists of dry disposal for human waste such as various chemical and incinerator type systems with separate disposal for grey water. However, regardless of the type of dry disposal system used, the grey water must be disposed of by primary and secondary treatment.

20.31 Limitation

- a. Waste segregation systems generally will only be considered for recreational type dwelling which receive seasonal use.
- b. If a waste segregation system is proposed for a structure other than recreational type dwelling, the system will be permitted only after being approved through the variances procedure set forth in Section 9 of this Regulation.

20.32 Design - Due to the production of grey water, waste segregation system shall meet all the design requirements of Section 9.22 of this Regulation with the following changes:

- a. A 40% reduction will be allowed in calculating septic tank size and absorption area.
- b. Technical factory literature of the type of system proposed will be required for review by the Department.

20.33 Operation - A written plan of maintenance and final disposal of humus must be provided.

20.4 Deep Absorption Fields - An absorption field whose trenches exceed thirty-six (36) inches in depth from the natural ground surface shall be considered a deep absorption field. This type of system may be considered where the depth to suitable soil is too great to permit the installation of a conventional absorption field due to the presence of a limiting layer more than two (2) feet in depth which overlies suitable soils of sufficient thickness.

20.41 Limitation - Deep absorption fields shall not be installed when:

- a. The limiting layer is greater than forty-eight (48) inches below the surface of the ground.
- b. The soils below the limiting layer have a percolation rate less than five (3) min/inch or greater than sixty (60) min/inch.
- c. High groundwater, bedrock, or any other limiting layer is within seventy-two (72) inches of the ground surface.

20.42 Design - Deep absorption fields shall meet all the design requirements of Section 9.22 of this Regulation with the following changes:

- a. Absorption trenches shall be excavated to a minimum of twelve (12) inches into suitable soil. At no time shall the depth of the absorption trench be greater than sixty (60) inches.
- b. The excavation shall be backfilled with a clean, washed, medium size sand to within thirty-six (36) inches of the ground surface.
- c. The minimum required absorption area shall be determined by the percolation rate of the soil below the limiting layer.

20.5. Sand Lined Absorption Field - Sand lined absorption fields will be considered when soils are determined to be a poor filter medium or when percolation tests show results faster than 3 min/inch. The Department may require sand lined absorption fields when groundwater is susceptible to wastewater contamination.

20.51 Limitation - Sand lined absorption fields shall not be installed when:

- a. Slopes are greater than 15%.
- b. High groundwater, bedrock, or other limiting layer is within sixty-six (66) inches of the ground surface.
- c. The sand shall be lined with a porous plastic filter fabric upon which the drainrock shall be placed.
- d. The minimum required absorption area shall be determined by the typical percolation rate of fine sand.

20.6 Cut Systems - This system may be utilized when the natural slope of the site is between 15 to 25%. The upper soil layers may be removed to modify the slope of the site. In the cut area, a type of absorption field described in this Regulation is installed.

20.61 Limitation

- a. Cut system shall not be installed when natural slopes are greater than 25%.
- b. The limitations of the particular absorption system proposed to be installed in the cut area shall apply.

20.62 Design

- a. Cut areas shall be physically complete for both the absorption field and the 100% replacement area prior to approval.

- b. The slope across the absorption field site shall be a uniform slope of less than 5%.
- c. The design requirements of the particular absorption system proposed to be installed in the cut area shall apply.

20.7. Dosed Systems - Dosing an absorption system ensures equal distribution of effluent throughout the system. Dosed systems have been shown to lengthen the "life" of an absorption system and are encouraged for all systems. Dosed systems have also been shown to increase the biological treatment of effluent in the absorption system. For this reason, the Department may require this system in marginal site conditions. Dosing shall be required when the required absorption area is between 1,000 to 1,500 square feet unless an alternating absorption field is used.

20.71 Limitation

- a. Dosed absorption systems shall not be installed when the absorption area required is greater than 1,500 square feet.
- b. The limitations of the particular absorption system proposed to be dosed shall apply.

20.72 Design - The design requirements of the particular absorption system proposed to be dosed shall apply.

- a. Dosing shall be accomplished by either pumps or siphons. The specifications of the dosing mechanism shall be submitted.
- b. The absorption system shall be dosed one to four times per day.
- c. The volume of each dose shall be the greater of the daily wastewater volume produced divided by the daily dosing frequency, or an amount equal to 3/4 of the internal volume of the distribution lines being dosed.
- d. The absorption trenches may be thirty-six (36) inches wide and the distribution lines shall be laid level.

20.73 Operation - Dosing frequency shall periodically be checked and recorded by the owner. An annual inspection of the pumping chamber is recommended.

20.8 Sloped Absorption Fields - This type of system shall include any absorption system to be installed on natural slopes between 15 to 25%.

20.81 Limitations

- a. The limitations of the particular absorption system proposed to be installed on a slope of between 15 to 25% shall apply.
- b. Sloped absorption fields shall not be permitted if the design report indicates the site is not suitable.

20.82 Design - The design requirements of the particular absorption system proposed to be installed on a slope of between 15 to 25% shall apply. In addition to this, a report from a qualified individual shall be prepared and submitted to the Department. The report shall include, but not be limited to,:

- a. The qualifications (academic background, experience, etc.) of the individual,
- b. The possibility of slope failure due to additional fluid entering the oil,
- c. Information on slope failures that have occurred in or near the area if available,
- d. The possibility of effluent surfacing based on expected hydraulic loading, the soil profile, the ground slope and any other pertinent information,
- e. The distance(s) to, classification(s) of, and characteristic(s) of the nearest receiving water(s) that may receive flow if the effluent surfaces,
- f. Direction of groundwater flow beneath the proposed absorption system,
- g. The distance to property lines, escarpments, and springs, streams, wells, ponds, or other hydrologic features located within a 500 foot radius of the proposed absorption system that may be influence by the effluent,
- h. The performance of any absorption systems in operation in the area.

SECTION 21
Experimental Alternative Systems

21.01 Experimental alternative systems are designed to overcome some of the limitations of conventional and standard alternative systems. They are placed in this class due to their complexity of design or due to limited knowledge with their effectiveness in Madison County.

21.011 Types

- a. Elevated Sand Mounds
- b. Evapo-Transpiration Systems
- c. Aerobic Package Plant Systems
- d. Artificially Drained Sites
- e. Intermittent Sand Filter Systems
- f. Recirculating Sand Filter Systems
- g. Nutrient Removal Systems
- h. Fill Systems
- i. Pressure Distribution Systems

21.012 Design - All systems in this category must be designed by and individual with expertise in the design of said system and may include engineers, sanitarians, soil scientists or other persons whose qualifications are demonstrated to the Department to be sufficient. ALL designers will be required to submit a resume of their education and expertise directly related to the design of alternative wastewater treatment systems.

Publications such as the EPA Design Manual On-Site Wastewater Treatment and Disposal Systems (October 1980), Recommended Standards for Individual Sewage Systems (1980 Edition, University of Wisconsin design and construction manuals, Design of Pressure Distribution Networks for Septic Tank -Soil Absorption Systems (January 1981) and the Design and Construction Manual for Wisconsin Mounds (September 1978) as published by the "Small Scale Waste Management Project" shall be used as design guidelines. Criteria within these manuals that conflicts with this Regulation shall not be used for design purposes.

21.013 Monitoring - Post construction inspections by the person who designed the system will be required of all systems in this category. In general, semiannual on-site inspections documenting usage, maintenance, system operation and malfunction or failure will be required of the designer. Groundwater analysis and/or other special monitoring requirements may be stipulated for some types of systems. Monitoring shall be conducted for a minimum of three years following completion of the system unless the system is not in continuous use hereby the period may be extended.

In all cases, the property owner shall be responsible for all monitoring costs incurred. A guaranteed commitment to monitoring must be established prior to the issuance of a permit. An escrow fund earmarked for monitoring purposes may be required to ensure that the experimental alternative system continues to function properly. The designer shall supply a cost breakdown for the monitoring and testing requirements set forth by the Department with the submittal. If an escrow account is required, evidence indicating the establishment of such a fund shall be submitted.

21.02 Elevated Sand Mound - Elevated sand mounds may be considered whenever site conditions preclude the use of a conventional or standard alternative system. The construction of a mound shall be initiated only after a site evaluation has been done and landscaping, dwelling placement, effect on surface drainage and general topography have been considered. Due to the nature of this system, actual selection of mound location, size of mound and construction techniques must be carefully considered and the criteria established in this Regulation implicitly followed.

21.021 Limitation

- a. Elevated sand mounds shall not be utilized on sites within 100 feet of the 100 year floodplain.
- b. Elevated sand mounds shall not be utilized on soils where the high groundwater level, bedrock, or other limiting layer occurs within forty-eight (48) inches of the natural ground surface.
- c. Minimum required separation distances shall be measured from the outer edge of the mound.
- d. Elevated sand mounds shall be located a minimum distance of ten(10) feet from property lines, buildings driveways or any other subsurface obstructions except that this distance shall be fifty (50) feet on the down gradient side of the mounds. No future construction activity is to take place in the effluent dispersal area described above for as long as the mound is in use.

21.022 **Fill Material** - The fill material to the depth of twenty-four (24) inches shall be a clean uniform sand (washed masonry or concrete sand with a maximum of 50% of the particles by weight equal to or less than 0.1 mm or greater than 0.05 mm (very fine sand). The remaining sand fragment shall consist of 0.1mm to 2.0mm particle size (fine to very coarse sand) with a minimum of 25% with a particle size of 0.25 mm to 0.6 mm (medium sand).

21.023 Design

- a. The EPA Design Manual On Site Wastewater Treatment and Disposal System (October 1980), pages 150 to 255 is recommended as a procedural guideline in the design of elevated sand mounds.
- b. There shall be a minimum of twelve (12) inches of fill material and forty-eight (48) inches of naturally occurring soils between the bottom of the drainrock and the highest elevation of the high groundwater bedrock, or other limiting layer.
- c. Elevated sand mounds shall utilize absorption trench distribution design and shall not be installed on land with a slope greater than 12% for permeable soils (1-29 min/inch) nor installed on land with a slope greater than 6% on tighter soils (30-120 min/inch). The trenches shall be installed with the long dimension of the trench parallel to the land contour. The minimum spacing between trenches shall be forty-eight (48) inches and the trench width shall be thirty-six (36) inches.
- d. A minimum total trench length of forty (40) feet shall be provided in each trench in mounds constructed in soils with percolation rates of 50 to 120 min/inch when two or more trenches are used.
- e. The required bottom area of the trench or trenches shall be based upon flows as determined by this Regulation with an application rate of 1.2 gallons/day/square foot.
- f. The effective basal area of the mounds for soils with a percolation rate of 5 to 44 min/inch is to be calculated on an application rate of 0.74 gallons/day/square foot.
- h. The effective basal area of the mound for soils with a percolation rate of 60 to 120 min/inch is to be calculated on an application rate of 0.24 gallons/day/square foot.
- i. The area fifty (50) feet down gradient of the elevated sand mound is the effluent dispersal area and soil in this area may not be removed or disturbed except as specified herein.
- j. The area of sand fill shall be sufficient to extend three (3) feet past the end of the required absorption area before sides are shaped to a four (4) horizontal to one (1) vertical or lesser slope. On sloping sites, the downslope setback shall be based upon soil permeability.
- k. The cap at the ends of the absorption area shall be a minimum of twelve (12) inches and shall be a minimum of eighteen (18) inches at the center of the mound. These depth include 4-6 inches topsoil.

1. Elevated sand mounds shall be pressure dosed in accordance with Section 21.10 of this Regulation.

21.024 Construction

- a. Construction equipment which would cause undesirable compaction of the soils shall not be moved across the plowed surface or the effluent dispersal area. However, after placement of a minimum of six (6) inches of sand fill over the plowed area, construction equipment may be driven over the protected surface to expedite construction. Construction and/or plowing shall not be initiated when the soil moisture content is high (Note: If a sample of soil obtained from approximately nine (9) inches below the surface can be easily rolled into a wire, the soil moisture content is too high for construction purposes.)
- b. Above ground vegetation must be closely cut and removed from the ground surface throughout the area to be utilized for the placement of the fill material. Prior to plowing or scarifying, the dosing pump discharge line from the pump chamber to the point of connection with the distribution piping header shall be installed. The area shall then be plowed or scarified to a depth of seven (7) to eight (8) inches, parallel to the land contour with the plow throwing the soil upslope to provide a proper interface between the fill and natural soils. Tree stumps should be cut flush with the surface of the ground and root should not be pulled.
- c. The area surrounding the elevated sand mound shall be graded to provide for diversion of surface runoff waters.
- d. All the required sand shall be placed immediately on the freshly prepared soil interface. After hand leveling of the absorption area, the drainrock shall be placed into the trench and hand leveled. Trench sidewalls shall be protected by placing synthetic filter fabric as a liner. Place the distribution pipe and cover as specified in Section 19.21 of this Regulation. After installation of the distribution system, the entire mound should be covered and carefully graded with six (6) inches of a finer textured soil material such as clay or silt loam. A six (6) inch layer of topsoil should then be added. The entire mound should be crowned by providing a minimum of twelve (12) inches of cover on the side slopes, with a minimum of eighteen (18) inches over the center of the mound. The entire mound shall be seeded, sodded, or otherwise provided with vegetative cover to assure stability of the installation.

- 21.03 Evapo-transpiration System - Evapo-transpiration systems (ET) or evapo-transpiration/absorption (ETA) systems may be considered whenever site conditions preclude the use of a conventional or standard alternative system. The construction of an ET or ETA system shall be initiated only after a site evaluation has been

done and landscaping, dwelling placement, effect on surface drainage or general topography have been considered. The most significant constraint on the use of ET or ETA systems is climatic conditions. During periods when evaporation does not exceed precipitation, long-term storage capacity will be necessary.

21.031 Limitation - Soils with very slow permeability may be considered for ETA systems. Soils with rapid permeability will not exclude the use of an ET system.

21.032 Fill Material - The fill material to a depth of twenty-four (24) inches shall be a clean uniform sand with a maximum of 50% of the particles by weight equal to or less than 0.1 mm and greater than 0.05 mm (very fine sand). The remaining sand fragment shall consist of 0.1 mm to 2.0 mm particle size (fine to very coarse sand) with a minimum of 25% with a particle size of 0.25 mm to 0.6 mm (medium sand).

21.033 Design

- a. A synthetic plastic liner of at least 10 mils thickness will be required for ET systems where the seasonal high groundwater is within six (6) feet of the natural ground surface or where rapidly permeable solids are present.
- b. There shall be a minimum of two (2) feet of naturally occurring soils between the bottom of the liner and the high groundwater level, bedrock, or other limiting layer.
- c. There shall be a minimum of two (2) feet of sand fill between the natural ground surface and the liner.
- d. The distribution pipe shall be surrounded by drainrock.
- e. ET and ETA systems shall utilize conventional absorption field design and shall not be installed on land with a slope greater than 12%. The trenches shall be installed with the long dimension of the trench parallel to the land contour. The minimum spacing between trenches shall be forty-eight (48) inches and a maximum trench width of twenty-four (24) inches shall be permitted.
- f. The area of the ET system will be based upon the pan evaporation minus precipitation for the wettest year in a ten year period. The area of an ETA system will be based upon the same data minus the estimated volume of effluent to be absorbed as determined by actual

percolation data from the site. Typically, storage capacity must be built into the system to accommodate months with low evaporation.

- g. A minimum cap of topsoil of six (6) inches shall be provided over the entire bed area.

21.034 Construction- ETA systems

- a. Excavation may proceed in clayey soils only when the moisture content is below the soils plastic limit. (Note: If a fragment of fragment of soil from nine inches below the ground surface can easily be shaped into the form of a wire, the soil moisture content is too high for construction purposes).
- b. A backhoe is usually used to excavate the system. Front-end loaders or bulldozer blades should not be used because the scraping action of the bucket or blade can smear the soil severely and the wheel or tracks compact the exposed infiltrative surface.
- c. Excavation equipment must not be driven on the bottom of the system. If trenches are used, the equipment can straddle the excavation. If a bed is used, the bed should be divided into segments so the machinery can always operate from undisturbed soil.
- d. The bottom of each trench or bed must be level throughout to ensure a more uniform distribution of the effluent. A level and tripod are essential equipment.
- e. The bottom and sidewalls of the excavation should be left with a rough open surface. Any smeared and compacted surface shall be removed with care.
- f. Work should be scheduled only when the infiltrative surface can be covered in one day, because wind-blown silt or raindrop impact can clog the soil.
- g. Once the infiltrative surface is properly prepared, the backfilling operations must be done carefully to avoid any damage to the soil.
- h. The drainrock used as a porous media is laid in by a backhoe or front-end loader rather than dumped in by truck. This should be done from the sides of the system rather than driving out onto the exposed bottom. In large beds, the gravel or rock should be pushed out ahead of small bulldozer.

- i. The distribution pipes are covered with a minimum of two (2) inches of drainrock.
- j. The drainrock is covered with a synthetic drainage fabric to prevent the unconsolidated soil cover from entering the media. The media shall be covered completely.
- k. The backfill material should be relatively porous soil such as a loamy sand or a sandy loam. It shall be mounded above natural grade to allow for settling and to channel runoff away from the system.
- l. ETA systems shall be pressure dosed in accordance with Section of this Regulation.

21.035 Construction-ET System

- a. Synthetic liners for ET systems must be cushioned on both sides with a layer of sand at least two (2) inches thick to prevent puncturing during construction. It may be preferable to use a double thickness of liner material so that the seams can be staggered if seams are unavoidable.
- b. Construction should be initiated immediately after preparation of the soil interface or liner by placing all the fill needed to a minimum depth of twenty-four (24) inches. Next trenches shall be excavated to a depth of twelve (12) inches for the placement of drainrock and the distribution pipe. Trench sidewalls shall be protected by placing synthetic filter fabric as a liner. The pipe shall be covered as specified in 21.034 of this Regulation.
- c. ET systems shall be pressure dosed in accordance with Section 21.10 of this Regulation.

21.04 Aerobic Package Plant Systems-Aerobic package plant systems may be used in lieu of a conventional septic tank whenever desirable due to marginal site conditions such as a minimum depth to high groundwater or very porous soil conditions. A means of securing continuous maintenance and operation of the system must be outlined.

21.041 Limitation - Separation to high groundwater, bedrock, or other limiting layer will be no less than forty-eight (48) inches as measured to the bottom of the trench. Soil permeability must be appropriate for the type of absorption system used.

21.042 Design

- a. The size of the absorption system will be determined according to Table 3 or Table 4 with no reduction allowed.
- b. All aerobic treatment systems shall be NSF Class 1, Standard 40 approved.

21.043 Operation - Aerobic treatment plants should be pumped at least once a year to remove excess solids from the plant.

21.05 Artificially Drained Site - Artificially drained systems may be considered whenever site conditions preclude the use of a conventional or standard alternative system. The construction of this type of system shall be initiated only after a site evaluation has been done and landscaping, dwelling placement, effect on surface drainage and general topography have been considered. It must be shown that the groundwater within the proposed absorption system area has been lowered to acceptable levels before final approval will be issued. Emphasis will be placed upon topographic surveys, soil profile descriptions, and seasonal high groundwater elevations and gradients. Large free moving bodies of water and artesian aquifers may not be suitable for this type of system.

21.051 Limitation - The drained area must lower groundwater to an acceptable level for the type of absorption systems proposed.

21.052 Design

- a. The EPA Design Manual On-Site Wastewater Treatment and Disposal Systems (October 1980) pages 260 to 268 is recommended as a guideline in the design of drained systems.
- b. A topographic map of the proposed absorption system and replacement site showing one (1) or two (2) foot intervals must be provided. Water table elevations, seep areas and areas with vegetation indicative of seasonal or prolonged high water table should be located on the map. Elevations of ridges, knolls, rock outcrops, and natural drainage ways should also be shown.
- c. Precise soil descriptions of the soil profile to a depth of ten (10) feet will be necessary. Soil stratification of layering color should be noted along with texture, density, saturated zones, and root penetration. The thickness and slope of each layer should be described. Soil mottling shall be noted.

- d. Groundwater elevation and gradient must be established through the observation of monitoring wells throughout the high groundwater period. Typically, several wells will be required, one placed up gradient of the site. Monitoring wells must be properly constructed so that accurate results are obtained. Levels should be checked weekly during the peak groundwater period. A drawing showing contours of the water table should be provided.
- e. The drainage method chosen (curtain drain, vertical drain, or underdrain) and the reason for this choice shall be detailed. Drawings showing dimensions of the drain system and materials to be utilized shall be provided to the Department.
- f. If the drain will be discharging to state waters, a discharge permit from the Montana Department of Health and Environmental Sciences will have to be obtained before a permit is issued.
- g. A separation distance of ten (10) feet must be maintained between the drain and the absorption system. Silt traps may be necessary to improve the quality of the discharged drainage.
- h. The design requirements of the particular absorption system proposed to be installed in the cut area shall apply.

21.053 Construction

- a. The drainage system shall be constructed according to the specific design approved by the Department and standards generally recommended by the EPA Design Manual.
- b. Permanent groundwater monitoring wells will be required for this type of system.

21.06 Intermittent Sand Filter System - The utilization of sand filters as a method providing additional treatment of effluent discharged from a septic tank or other primary treatment device may be considered whenever site conditions preclude the use of a conventional or standard alternative system. The design criteria shall include, but not be limited to, the type of usage, primary treatment, filter media, filtration rate, and dosage rate. Sand filters must discharge to an absorption system. The absorption system used for final disposal may be downsized by 50% as determined by Table 3 and Table 4.

21.061 Limitation

- a. Intermittent sand filters (ISF) shall not be utilized on sites within 100 feet of the 100 year flood plain.

- b. ISF systems shall not be installed in areas where high groundwater, bedrock, or other limiting layer occurs within sixty (60) inches of the natural ground surface.

21.062 Design

- a. The minimum area in any intermittent sand filter shall be based upon a flow as determined in Section 18.42 of this Regulation.
- b. The application rate for intermittent sand filters shall not exceed 1.2 gal/day/square foot. The sand filter media shall meet ASTM C-33 specifications and shall not have more than 45% passing any one sieve and restrained on the next consecutive sieve.
- c. Collection lines and the bottom of the excavation shall have a slope of 1% and one collection line shall be provided for each six (6) feet of width or fraction thereof. A minimum of two collection lines shall be provided. The upper end of the collection line shall be sealed or plugged.
- d. Distribution lines shall be level and shall be horizontally spaced a maximum of thirty-six (36) inches apart, center to center.
- e. The minimum depth of filter material shall be twenty-four (24) inches. The filter media shall be separated from the drainrock by three (3) inches of 1/4 inch pea gravel.
- f. A 30 mil PVC liner shall be used to line the sand filter. A reinforced concrete container shall be required where the filter must be protected from groundwater infiltration.
- g. ISF systems shall be pressure dosed in accordance with Section 21.10 of this Regulation.

21.063 Construction

- a. Gravel or crushed stone shall be placed at a minimum depth of ten (10) inches around distribution and collection lines.
- b. The filter shall be covered with twelve (12) to eighteen (18) inches of soil.
- c. Monitoring pipes to detect filter clogging will be required.

21.064 Materials

- a. The filter media shall have a uniformity coefficient of less than 3.5. The filter material shall be washed and free of silt or clay.

- b. Gravel or crushed stone shall be washed and shall range in size from 3/4 to 1 1/2 inches for the distribution lines and shall range in size from 1/4 to 1 1/2 inches for the underdrain lines.
- c. Pea gravel shall be washed and range in size from 1/8 to 3/8 inch.
- d. The material used to cover the top of the gravel or crushed stone shall be synthetic filter fabric, one layer of untreated building paper, or a full (two) inches of compacted straw.
- e. Pipe used for distribution and collection lines shall meet the appropriate ASTM standards or those of an equivalent testing laboratory. Fittings used shall be compatible with the materials used in the distribution and/or collection lines.
- f. Materials selected shall be constructed of cement or rigid plastic pipe. If perforated collection lines are used, the perforation shall be at least 1/2 inch and no more than 3/4 inch in diameter and spaced to provide at least the equivalent total opening of comparable foot-long tile laid with 1/4 inch open joints.

21.07 Recirculating Sand Filter Systems - When a recirculating sand filter is used, effluent from the septic tank or other primary treatment device must discharge directly to the recirculation tank. The minimum criteria relative to the limitations, design considerations, materials, dosing, and general construction details provided for intermittent sand filters shall also apply to recirculating sand filters except as follows:

- a. The design of recirculating sand filter is similar to the design of an intermittent sand filter except that it must be located to permit gravity flow into the top of the recirculation tank from the collection line of the filter.
- b. The depth of the filter media shall be at least thirty (30) inches.
- c. The maximum application rate shall be 3 gal/day/square foot of filter area.
- d. The liquid capacity of the recirculation tank shall be the greater of either 750 gallons or 1 1/2 times the daily design wastewater flow.

- e. The filter effluent line, passing through the recirculation tank, shall be provided with a control device that directs the flow of the filter effluent. The filter effluent will be returned to the recirculation tank for recycling or be discharged to the absorption system depending on the liquid level in the recirculation tank.
- f. The recirculating pump shall be of adequate size to recirculate the daily design wastewater flow at least four times through the sand filter. The recirculating pump shall be sized to dose the filter every thirty minutes (within a ten minute period as a margin of error). The dose volume is, therefore, 4 times the daily flow divided by 48. Dosing frequency may be reduced as dictated by climatic conditions to minimize the possibility of freezing of the filter surface.
- g. The effluent shall be discharged in such a manner as to provide uniform distribution through a system of pipes or troughs supported above the filter surface.
- h. The filter surface which is sand rather than gravel must be raked and leveled on a routine basis. The filter shall be kept free of weed growth and the accumulation of all debris. Where climatic conditions dictate the installation of a cover, it shall be constructed to minimize freezing, support anticipated snow loads, and permit air circulation. After extended periods of operation, a crust may develop on the surface of the sand in some areas. When ponding occurs, the upper 1/2 to 1 inch of crust and sand should be leveled and the process continued until a minimum of twenty-four (24) inches of sand remains. At that time, the filter shall be reconstructed by adding new sand and the operation of the filter reinstated.
- i. A small hole shall be provided on the pump discharge line inside the recirculation tank to allow the discharge line to drain back into the recirculation tank.

21.08 Nutrient Removal System - Nutrient removal systems may be used when use of an absorptions system is likely to degrade water quality. In general, absorption systems located in close proximity to lakes may require additional nutrient removal especially where very permeable soil are present. A means of securing continuous maintenance and operation of the system must be outlined.

21.081 Limitation - Separation to high groundwater, bedrock, or other limiting layer will be no less than forty-eight (48) inches as measured to the bottom of the trench. Soil permeability must be appropriate for the type of absorption system used.

21.082 Design

- a. Specific design criteria will not be outlined in this Regulation. The EPA Manual -On-Site Wastewater Treatment and Disposal Systems (October 1980), pages 184 to 198 will be used as a guideline for the design of these systems. Established research documents may also be utilized as a basis for design.
- b. Monitoring of these systems will be required in order to establish their efficiency.

21.09 Fill System - Fill systems may be considered whenever site conditions preclude the use of a conventional or standard alternative system. The construction of a fill system shall be initiated only after a site evaluation has been done and landscaping, dwelling placement, effect on surface drainage and general topography have been considered.

21.091 Limitations

- a. Any parcel that will undergo land modification by filling must have enough area suitable for absorption system placement. The entire area necessary for the primary absorption system plus area of 100% replacement must be filled prior to issuance of a permit.
- b. Fill systems shall not be installed on land with a slope greater than 12%. Sites with less permeable soils (30-60 min/inch) shall not have slopes in excess of 6%.
- c. Fill systems shall not be utilized on soils where the high groundwater level, bedrock, or other limiting layer occurs within forty-eight (48) inches of the natural ground surface.

21.092 Fill Material

- a. Fill material shall be of similar porosity and texture as the underlying natural soil. Clay content shall not exceed 10% by weight. Fill material with significant amounts of cobbles and boulders (15% or more) is unacceptable.
- b. Prior to the placement of fill material, the texture of both the native soil and the proposed fill must be established. This shall be done by particle size distribution analysis (sieve test) of representative soil samples.

21.093 Design

- a. System configuration, dimensions, and orientation must be approved prior to the placement of fill material.

- b. Fill must be of suitable depth to provide seven (7) feet of soil from the finished ground surface to high groundwater, bedrock, or other limiting layer.
- c. After the specified settling period, at least one ten (10) foot test hole shall be excavated within the proposed absorption system site. This test hole shall be inspected to determine if remnants of surface vegetation are present or if suitable soil structure is not attained.
- d. Two percolation tests shall be performed as a basis of design application rate.

21.094 Construction

- a. All vegetative cover must be removed from the area to be filled.
- b. Fill material must not be put in place when it is frozen.
- c. Fill material must be allowed to set undisturbed for a 24 month period prior to the installation of an absorption system. If the fill material is placed in lifts as specified by an engineer so as to obtain natural soil structure conditions, the 24 month settling period may be waived by the Department.
- d. Absorption trenches shall be setback at least twenty-five (25) feet from the upper edge of the filled area.
- e. The fill area shall be seeded or sodded to a suitable grass to aid in stabilization.

21.10 Pressure Distribution Systems - Pressure dosing may be considered in lieu of gravity feed distribution whenever desirable due to marginal site conditions or for the purpose of extending the life of the system. Pressure dosing shall be required when the required absorption area is greater than 1,500 square feet. Those experimental alternative systems which require pressure dosing in their design shall follow these design criteria.

21.101 Limitation - Pressure distribution systems shall have the same limitations as the particular absorption system being proposed and acceptable percolation rates may be between one (1) min/inch and ninety (90) min/inch.

21.102 Design

- a. The design requirements of the particular absorption system proposed to be dosed shall apply except that absorption trenches may be thirty-six (36) inches wide and the distribution lines shall be laid level.

- b. The field shall be dosed not more than four times per day.
- c. The dose volume shall be equal to the drained volume of the discharge pipe and manifold plus a volume that should be ten times but shall not be less than five times the distribution pipe volume.
- d. The size of the dosing pumps or siphons shall be selected to provide a minimum pressure of one psi (2.3 feet of head) at the end of each distribution line. The specifications of the dosing mechanism shall be submitted.
- e. The pressure distribution pipe shall be PVC pipe. The pipe shall have a single row of perforations 3/16 inch diameter or larger in a straight line. Maximum perforation spacing shall be five (5) feet. An equivalent design that assures uniform distribution may be provided with the approval of the Department.
- f. The time of each discharge shall not exceed 15 minutes to promote uniform distribution.
- g. A hydraulic analysis demonstrating uniform distribution shall be provided. The analysis shall show no greater than 10% variation in distribution across the entire absorption field.
- h. Distribution pipes at the corners and side midpoints of dosed absorption fields shall have capped inspection risers that terminate slightly below ground surface. A metal location marker shall be provided for each inspection riser.

SECTION 22 Multi-user Systems

22.1 Plans for multi-user wastewater treatment systems must be approved by the Department. Plans for "Public Sewage Disposal Systems" as defined herein, must be reviewed and approved by the Montana Department of Health and Environmental Sciences. Plans are to be designed in accordance with this Regulation and the requirements of the Montana Department of Health and Environmental Sciences.

SECTION 23
Restricted Systems

23.1 The systems addressed in this section are to be considered only after all other options are eliminated.

23.2 Absorption Beds - Absorption beds are used primarily on lots with limited area. Beds differ from trenches in that they are wider than twenty-four (24) inches and have more than one distribution line. This system will be permitted only after being approved through the variance procedure set forth in Section 9 of this Regulation.

23.21 Limitations

- a. Absorption beds will only be considered when a secondary treatment system utilizing absorption trenches is not feasible due to limited area. The Department shall make this determination.
- b. Absorption beds shall not be installed in soils having a percolation rate less than five (5) min/inch or greater than sixty (60) min/inch, when slopes are greater than 8%, or when high groundwater, bedrock or any other limiting layer is within sixty-six (66) inches of the ground surface.

23.22 Design - Absorption beds shall be designed similarly to the absorption trenches (see Section 19.21) with the following changes:

- a. Width of the bed shall be determined on a case-by-case basis using the equation $C \geq 0.75 \times A$ where C = circumference of the bed in feet and A = area of the bed in square feet.
- b. A connected loop of distribution line shall be placed one (1) foot from the sidewall. Inside this loop, distribution lines shall be spaced at intervals no greater than three (3) feet.
- c. The distribution lines shall be laid level.
- d. No machinery shall be driven on the excavation of the bed.

23.3 Seepage Pits - Seepage pits are deep excavations used for subsurface disposal of pretreated wastewater. Covered porous walled chambers are placed in the excavation and surrounded by rock. Wastewater enters the chamber where it is stored until it seeps into the surrounding soil. This system is used primarily on lots with limited area. This system will be permitted only after being approved through the variance procedure set forth in Section 9 of this Regulation.

23.31 Limitations

- a. Seepage pits will only be considered when a secondary treatment system utilizing absorption trenches is not feasible due to limited area. The Department shall make this determination.
- b. Seepage pits may not be used in environmentally vulnerable areas or areas of high permeability soils.
- c. High groundwater shall be a minimum of twenty-five (25) feet below the proposed bottom of the seepage pit.

23.32 Design

- a. The absorption area required shall be determined by using the soil profile. Each soil layer's estimated percolation rate will be weighted to find the average percolation rate for the soil used by the seepage pit.
- b. Effective absorption area of a seepage pit shall be calculated as the area of the side-walls below the inlet.
- c. When more than one seepage pit is required, a minimum separation distance equal to three times the diameter of the largest seepage should, if possible, be maintained between seepage pits.
- d. The outside of the chamber shall have a minimum of three (3) feet of clean rock or gravel around its perimeter.
- e. The porous chamber to be used shall be of precast concrete. Cement used in the concrete shall meet requirements of ASTM C 150, Type II or Type V with a maximum tricalcium aluminate content of five (5) percent.

23.4 Holding Tanks - Holding tanks are not a means of wastewater treatment and disposal. Instead, they function as a storage device for wastewater. When full, the contents of the tank has to be pumped out by a septic system pumper licensed with the Montana Department of Health and Environmental Sciences.

23.41 Limitations

- a. Due to the high volume of wastewater produced at residences and the expense of continually pumping the tank, this system will not be considered for year-round residences.
- b. Siting requirements shall be the same as those for septic tanks.

23.42 Design

- a. The holding tank must be stabilized against flotation, waterproofed against infiltration or exfiltration.

- b. The capacity in gallons of the holding tank shall be determined by the Department on a case-by-case basis.
- 23.43 Operation - The owner will be required to sign an agreement stating that they will:
- a. Test the holding tank for tightness on an annual basis (the means of testing shall be specified), and,
 - b. Submit proof of pumping to the Department on an annual basis and,
 - c. Connect to a public system when collection mains become accessible (within 500 feet) if permission is granted by the entity controlling the system.
- 23.5 Sealed Pit Privies - Sealed pit privies consist of an enclosed receptacle to receive non-water carried toilet wastes into a lined vault.
- 23.51 Limitation - Sealed pit privies shall be considered for facilities which do not have a piped water supply.
- 23.52 Design - The vault used to hold the wastes shall be water tight.

SECTION 24

- 24.1 Wastewater treatment systems not specifically addressed in this Regulation shall be classified as innovative alternative systems. This class of system was established to enable designers to pursue new and creative ideas in the area of wastewater treatment. Innovative alternative systems shall provide, at minimum, primary and secondary treatment.
- 24.11 Limitation
- a. A maximum of five (5) innovative alternative system will be permitted in Madison County per calendar year.
 - b. If an innovative alternative treatment system for which a permit has been issued has not been installed, inspected and approved within 6 months the permit shall be voided by the Department.
- 24.12 Design-The Department will consider innovative alternative systems for approval if:
- a. All systems in this category must be designed by an individual with expertise in the design of said system and may include engineers, sanitarians, soil scientists or other

persons whose qualification are demonstrated to the Department to be sufficient. ALL designers will be required to submit a resume of their education and expertise directly related to the design of alternative wastewater treatment systems.

- b. The applicant provides adequate information to the Department that insures the system will effectively treat the wastewater in a manner that will prevent groundwater contamination and will meet all the requirements of Section 1.2 of this Regulation.
- c. The applicant provides a method, acceptable to the Department, to determine the effectiveness of the system.
- d. The required fees are submitted to the Department. (Note: Fees for innovative alternative systems shall be assessed on a case-by-case basis. Generally, the fee shall be the same as an experimental alternative system plus any additional costs incurred by the Department. Additional costs shall include, but not be limited to, monitoring costs, contracted technical assistance, and analytical costs (lab fees). (Fees will be negotiated before the Department incurs any costs.)

24.13 Operation

- a. Post construction inspections by the person who designed the system will be required of all systems in this category. In general, semiannual on-site inspections documenting usage, maintenance, system operation and malfunction or failure will be required of the designer. Groundwater analysis and/or other special monitoring requirements may be stipulated for some types of systems. Monitoring shall be conducted for a minimum of five years following completion of the system unless the system is not in continuous use whereby the period may be extended.
- b. The applicant shall allow the Department access to the innovative alternative system for a period of up to (5) five years for the purpose of insuring compliance of this Regulation.
- c. In all cases, the property owner shall be responsible for all monitoring costs incurred. A guaranteed commitment to monitoring must be established prior to the issuance of a permit. An escrow fund earmarked for monitoring purposes may be required to ensure that the experimental alternative system continues to function properly. The designer shall supply a cost breakdown for the monitoring and testing requirements set forth by the Department with the submittal. If an escrow account is required, evidence indicating the establishment of such a fund shall be submitted.

- d. A applicant shall meet all the conditions stated on the permit.

SECTION 25 Replacement Systems

- 25.1 A replacement system is a wastewater treatment system proposed to replace a failed, failing, or contaminating system.
- 25.2 Replacement system shall be designed and constructed to allow the best treatment practical. Absorption fields will be considered first for all situations.
- 25.3 If the sewer from the building is at a depth which mandates an absorption system depth of greater than thirty-six (36) inches, the Department may allow a maximum trench depth of sixty (60) inches.
- 25.4 If there is insufficient room for an absorption field, an absorption bed shall be give consideration before a seepage pit.
- 25.6 A vertical separation of forty-eight (48) inches from the bottom of the absorption system and high groundwater, bedrock, or other limiting layer is required.
- 25.7 The Department may require that any component of the wastewater treatment system be upgraded if said component may fail or cause failure.

APPENDICES

Appendix A	Percolation Test Procedures
Appendix B	Schedule of Fees
Appendix C	Septic Tank Design
Appendix D	Drawings
Appendix E	Soil Description

APPENDIX A
Percolation Test Procedure

General - Properly conducted percolation test are needed to determine absorption system suitability and to size the absorption system.

Test Hole Preparation

1. Dig or bore holes approximately six (6) inches in diameter with vertical sides. Depth of holes shall be equal to the depth of the proposed absorption system. (Example: The test hole for a shallow capped absorption field should be dug or bored to a depth of twelve (12) to eighteen (18) inches.)
2. Roughen or scratch the bottoms and sides of the holes to provide natural, unsmoothed surfaces. Remove loose material. Place about two (2) inches of 1/2 to 3/4 inch washed gravel in the bottom of the holes to prevent scouring during water addition.
3. Establish a reference point for measurements in each hole.

Soaking

1. Fill holes with clear water to a level of at least twelve (12) inches above the gravel.
2. In sandy soils, add twelve (12) inches of water a second time. If the second filling seeps away in ten (10) minutes or less, proceed with test.
3. In other soils, maintain at least twelve (12) inches of water in the hole for at least four hours to presoak soil. Do not remove water remaining after four hours. Permit soil to swell at least twelve hours.

Test

1. Sandy Soils

- a. Add water to provide a depth a six (6) inches above gravel and measure water level drop in ten minutes. Repeat this procedure for one hour.
- b. Use a shorter time interval if the first six (6) inches seeps away in ten minutes or less. Do not exceed the six (6) inch depth of water.
- c. Use the final water level drop to calculate the percolation rate.

2. Other Soils

- a. Remove loose material to top of gravel.

APPENDIX A

continued

- b. Adjust water level to six (6) inches above gravel and measure water level drop in thirty minutes. Repeat this procedure for four hours or until two successive drops do not vary by more than 1/16 inch (stabilized rate achieved).
- c. If the first six (6) inches of water seeps away in less than thirty minutes, use a ten minute interval and run for one hour.
- d. Refill with water only when necessary. Do not exceed the six (6) inch depth of water. Adjust water for the last three measurement periods such that they start with the same depth. Use final water level drop to calculate percolation rate.

RECORDS

1. Date(s) of test (s),
2. Location and depth of each test hole,
3. Time of day that each soak period began and ended.
4. Time of day for beginning and end of each water level drop interval,
5. Each water level drop measurement,
6. Name of person performing test,
7. Name of applicant.

Rate Calculation

$$\text{Percolation Rate} = \frac{\text{Time Interval in Minutes}}{\text{Water Level Drop in Inches}}$$

**APPENDIX B
Schedule of Fees**

Determining Permit Fees

Conventional System.....	Add	0
Standard Alternative System.....	Add	1
Experimental Alternative System.....	Add	3
Restricted System.....	Add	1
Innovative Alternative System.....	Add	3
Parcel has Certificate of Subdivision Plat Approval.....	Add	0
Parcel does not have Certificate of Subdivision Plat Approval.....	Add	1
Licensed Installer.....	Add	0
Homeowner Installer.....	Add	2
Multi-User.....	Add	(gpd X 0.00050*

Point Total (PT) _____

Permit Fee

Original Fee.....	(\$80.00 + (PT X \$25.00))
Continuation Fee.....	\$25.00

Service Fees

Reinspection Fee.....	\$35.00
Site Evaluation.....	\$50.00** plus mileage
Groundwater Monitoring(per site).....	\$75.00

Installer Fees

Yearly License Fee.....	\$50.00
-------------------------	---------

* Round up to the near whole number

** Includes soil profile observation, slope measurement, and flood potential. Does not include percolation tests, system design or determining high groundwater.

Note: When two or more systems are used in conjunction with each other, fees will be determined by adding the point values of both systems. If the design criteria of a system specifically integrates the use of another system (i.e. pressure dosing an elevated mound system.) then the fee will be based on the point value of the system whose design integrates the other system.



APPENDIX C
continued

Symbols and Abbreviations

D.	interior depth of tank from bottom of outlet invert	MIN	minimum
L	interior length of tank	MAX	maximum
W	interior width of tank	PVC	polyvinyl chloride

Notes:

- #1 Depth greater than 78 inches shall not be used in computing tank capacity.
- #2 Rectangular tanks: 0.2 D
Horizontal cylindrical tanks: 0.15 D
- #3 Rectangular tanks: 0.35 D
Horizontal cylindrical tanks: 0.3 D
- #4 Tanks may be equipped with baffles that meet the shown dimensional requirements. Horizontal dimensions apply to the side of the baffle nearest to the tank wall.
- #5 Access port cover elevation shall be adjusted as necessary with riser sections added if the depth is greater than 18 inches.
- #6 An access port is required for each compartment unless one access port can adequately access more than one compartment. Covers shall be provided with a lifting eye.
- #7 Compartment wall is optional. When provided, the minimum capacity of the first compartment shall be 500 gallons.
- #8 Liquid connection between compartments shall consist of a single completely across the compartment wall or two or more openings equally spaced across the wall. Total area of openings shall be at least three times the area of the inlet pipe.

(APPENDIX B
Schedule of Fees)

Determining Permit Fees

Conventional System.....	Add	0
Standard Alternative System.....	Add	1
Experimental Alternative System.....	Add	3
Restricted System.....	Add	1
Innovative Alternative System.....	Add	3
Parcel has Certificate of Subdivision Plat Approval.....	Add	0
Parcel does not have Certificate of Subdivision Plat Approval..	Add	1
Licensed Installer.....	Add	0
Homeowner Installer.....	Add	1
Multi-User.....	Add	(gpd X 0.00050*

Point Total (PT) _____

Permit Fee

Original Fee.....	(\$80 + (PT X 25)]
Continuation Fee.....	\$25.00

Service Fees

Reinspection Fee.....	\$35.00
Site Evaluation	\$50.00**
Groundwater Monitoring.....	\$75.00

Installer Fees

Yearly License Fee.....	\$50.00
-------------------------	---------

* Round up to the near whole number

** Includes soil profile observation, slope measurement, and flood potential. Does not include percolation tests, system design or determining high groundwater.

Note: When two or more systems are used in conjunction with each other, fees will be determined by adding the point values of both systems. If the design criteria of a system specifically integrates the use of another system (i.e. pressure dosing an elevated mound system.) then the fee will be based on the point value of the system whose design integrates the other system.

APPENDIX D
Drawings

D-1	Soil Key
D-2	Shallow-Capped Absorption Field
D-3	Shallow-Capped Absorption Field
D-4	Sand Lined Absorption Field
D-5	Deep Absorption Field
D-6	Absorption Field on a Level Site
D-7	Absorption Field with Drop Boxes
D-8	Absorption Field with Distribution Boxes
D-9	Site Plan with Setback Distances

APPENDIX C
Septic Tank Design

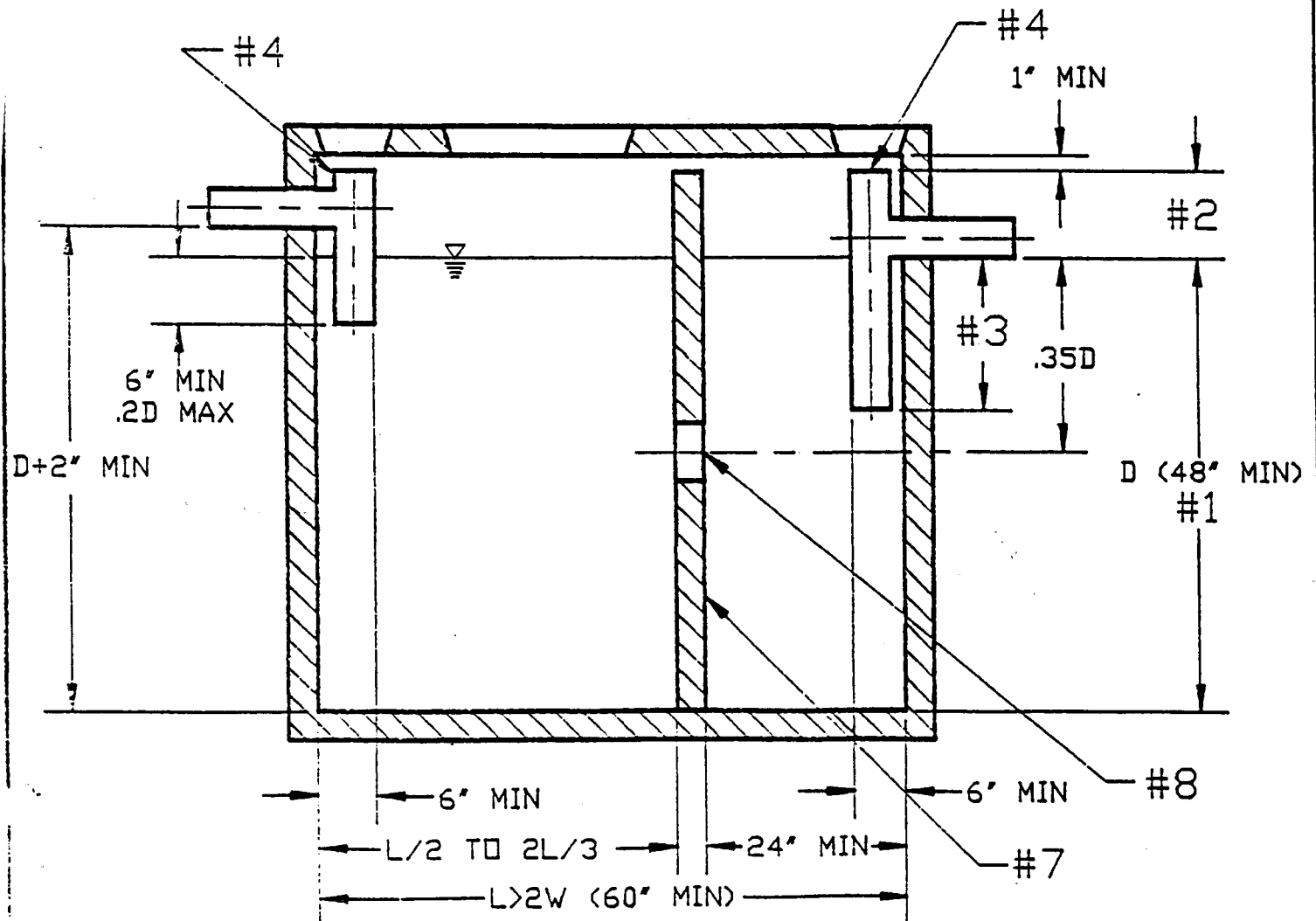
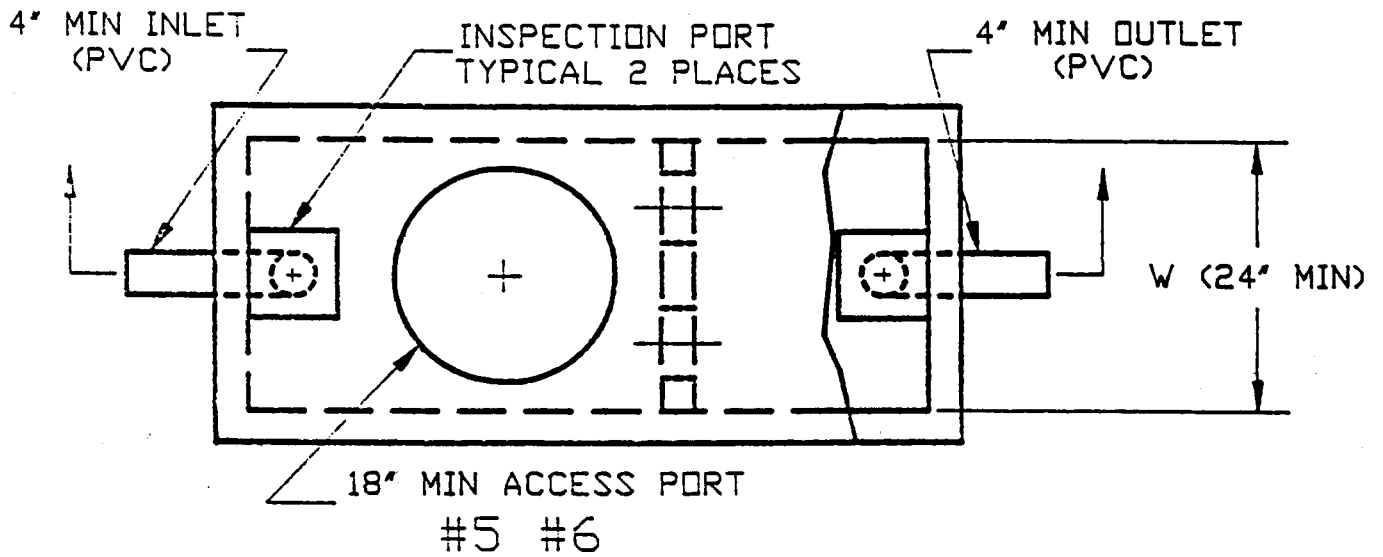

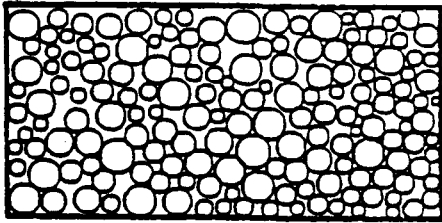

3/4'-2 1/2' WASHED ROCK

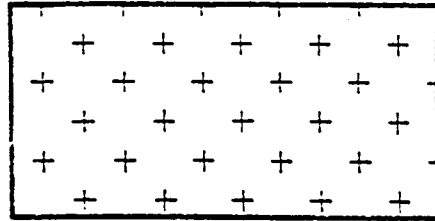

SUITABLE SOIL

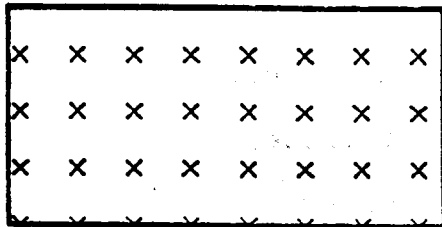

BACKFILL

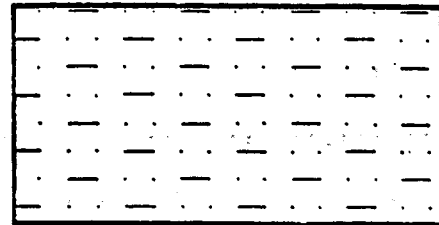

CLEAN WASHED SAND

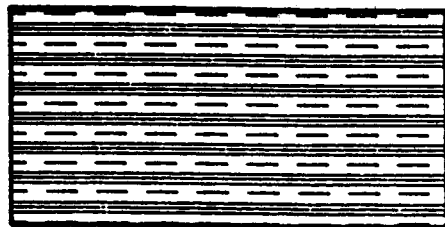

**SOIL WITH PERC RATE
OF > 60 MIN/INCH**

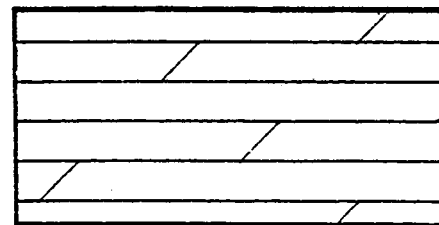

**GROUND WATER, BEDROCK
OR LIMITING LAYER**

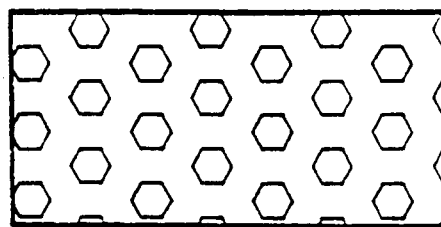

**SOIL WITH PERC RATE
OF < 3 MIN/INCH**

SOIL KEY

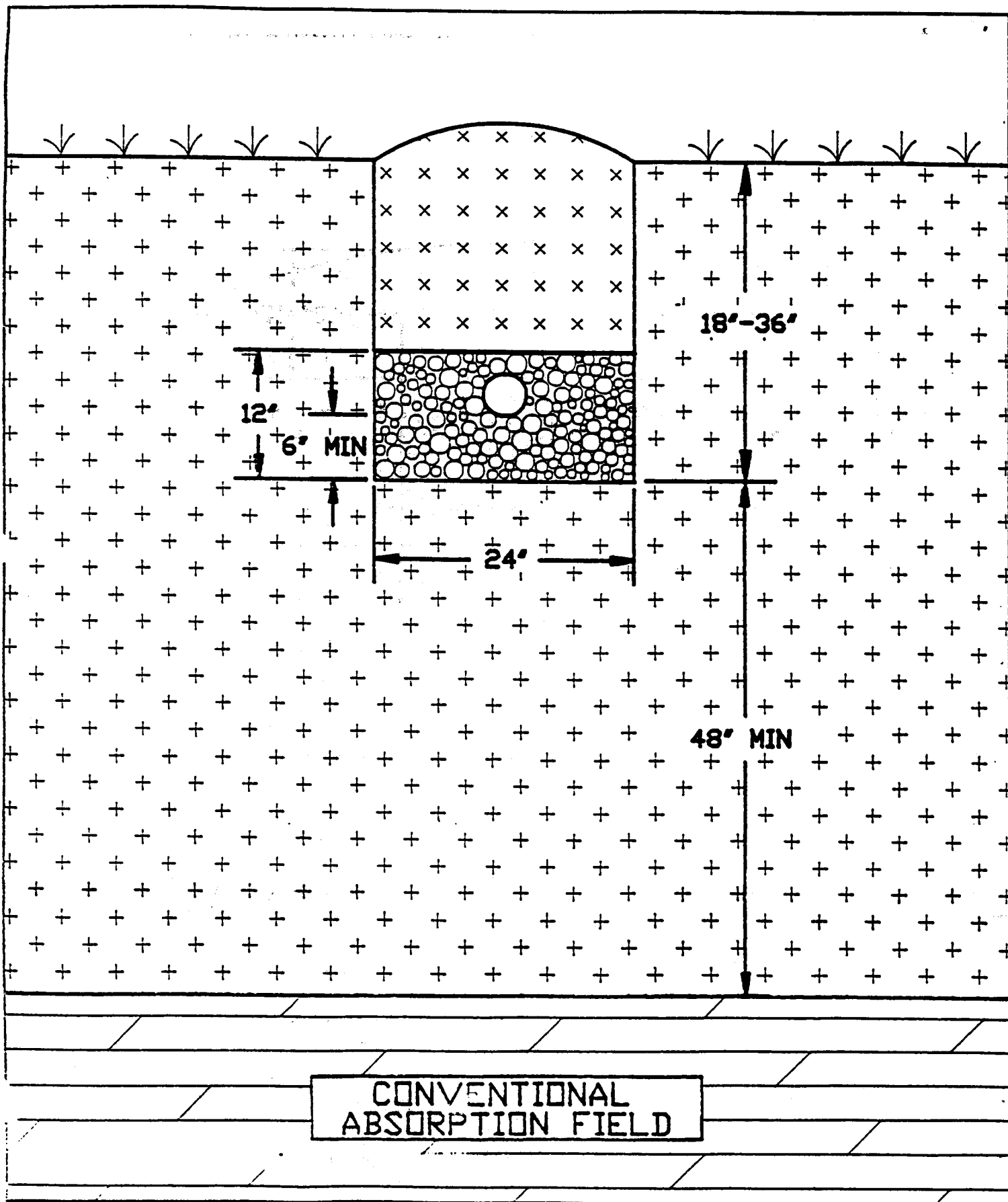

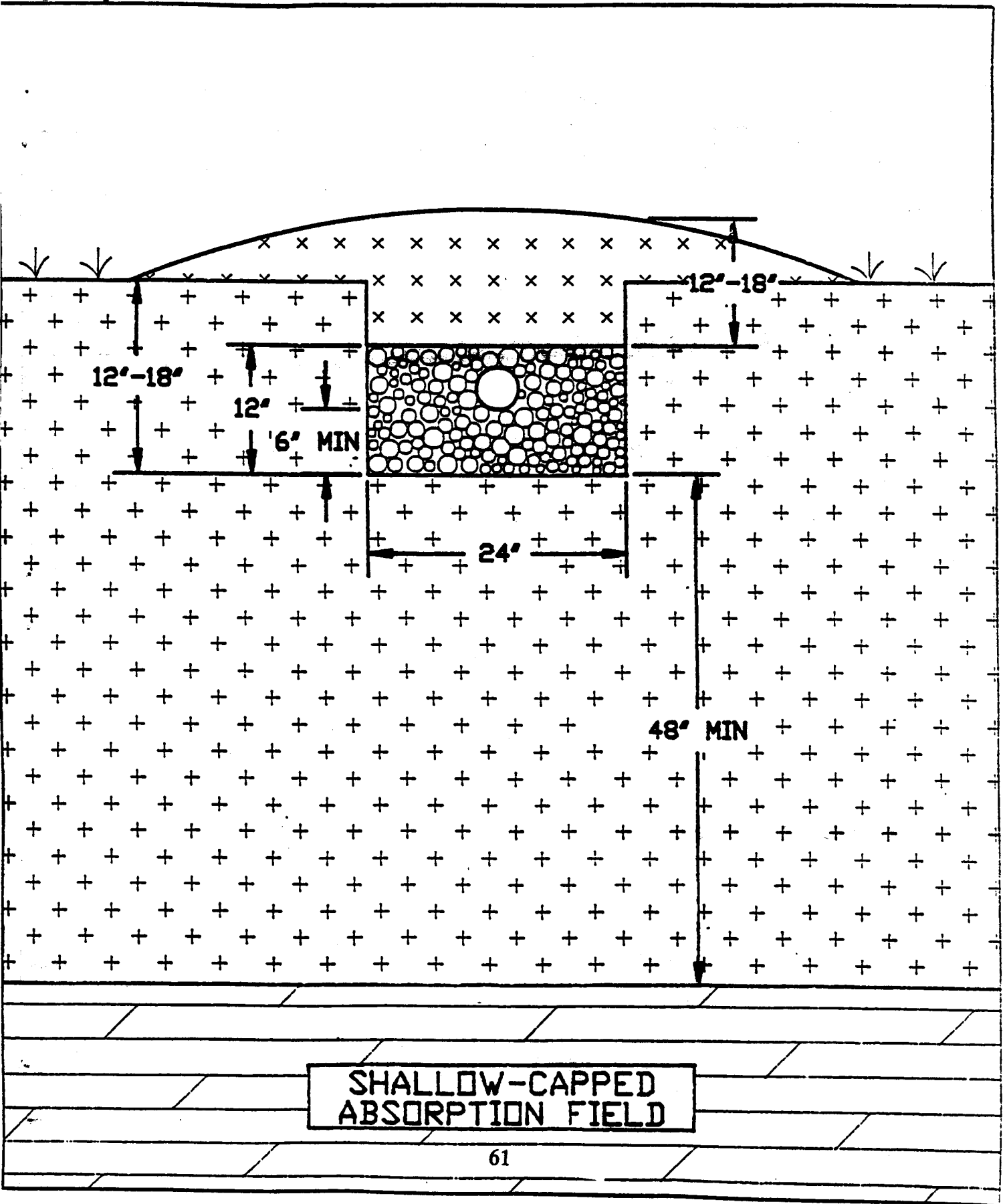

SHALLOW-CAPPED
ABSORPTION FIELD

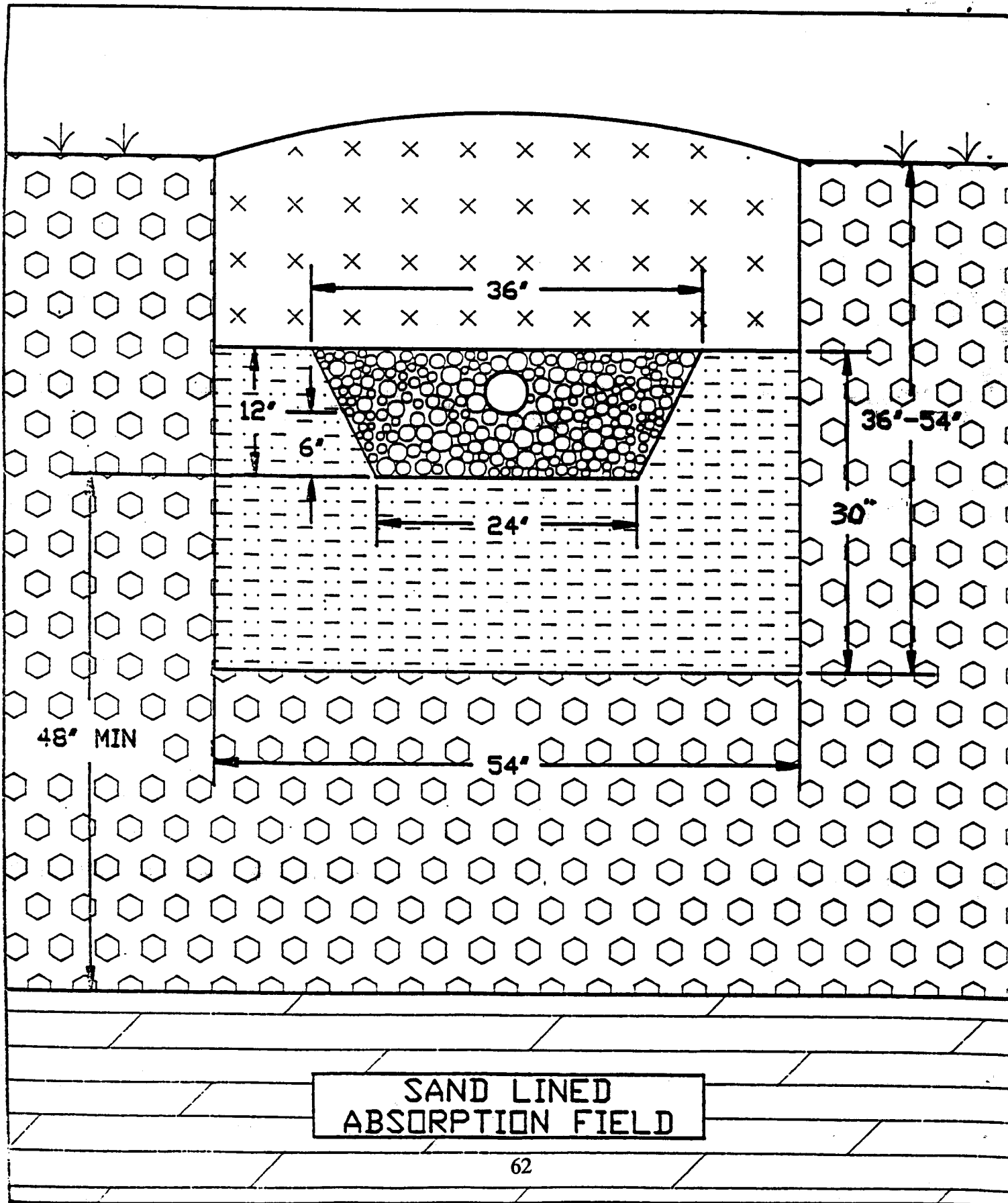

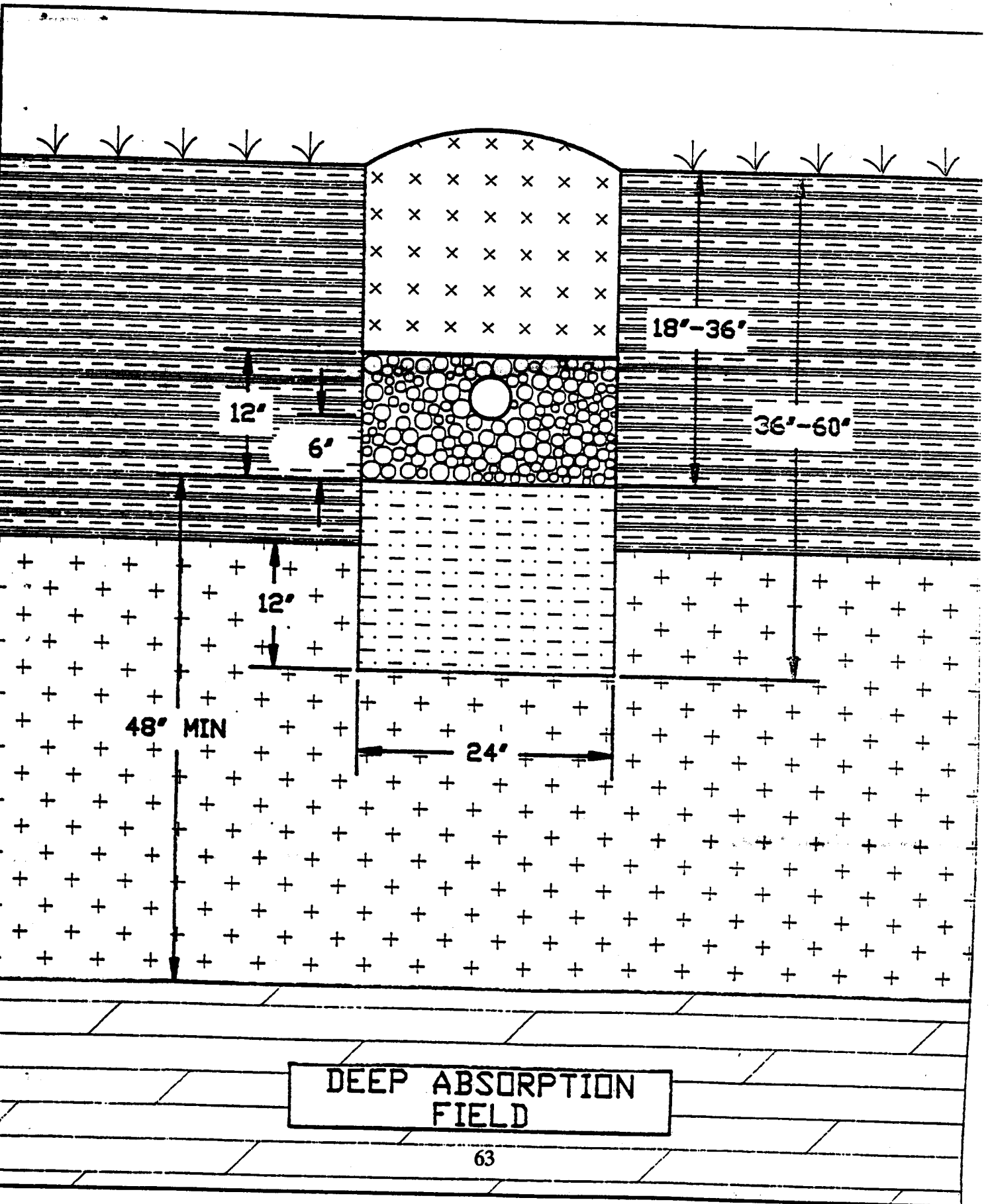

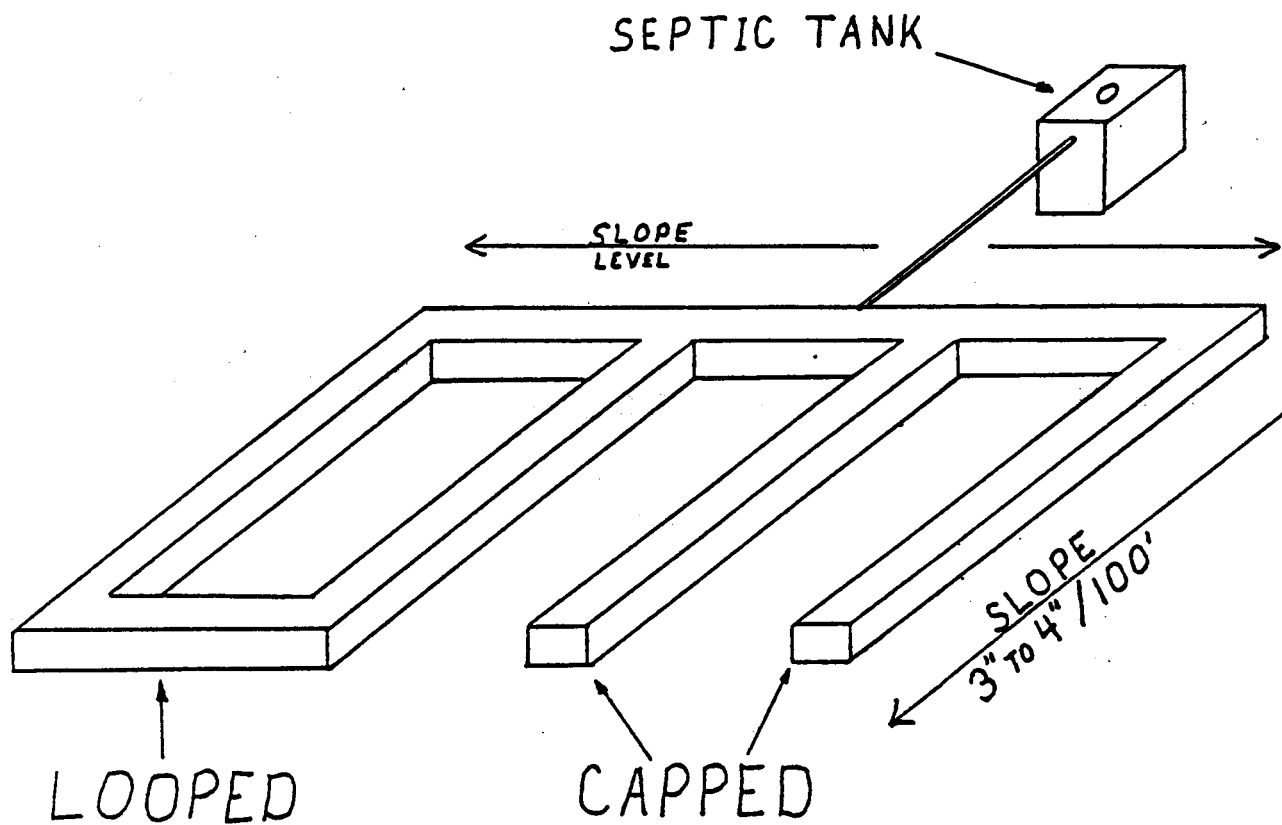

ALL TRENCH ENDS SHALL EITHER BE CAPPED OR PREFERABLY LOOPED WHEN POSSIBLE

LEVEL SITE

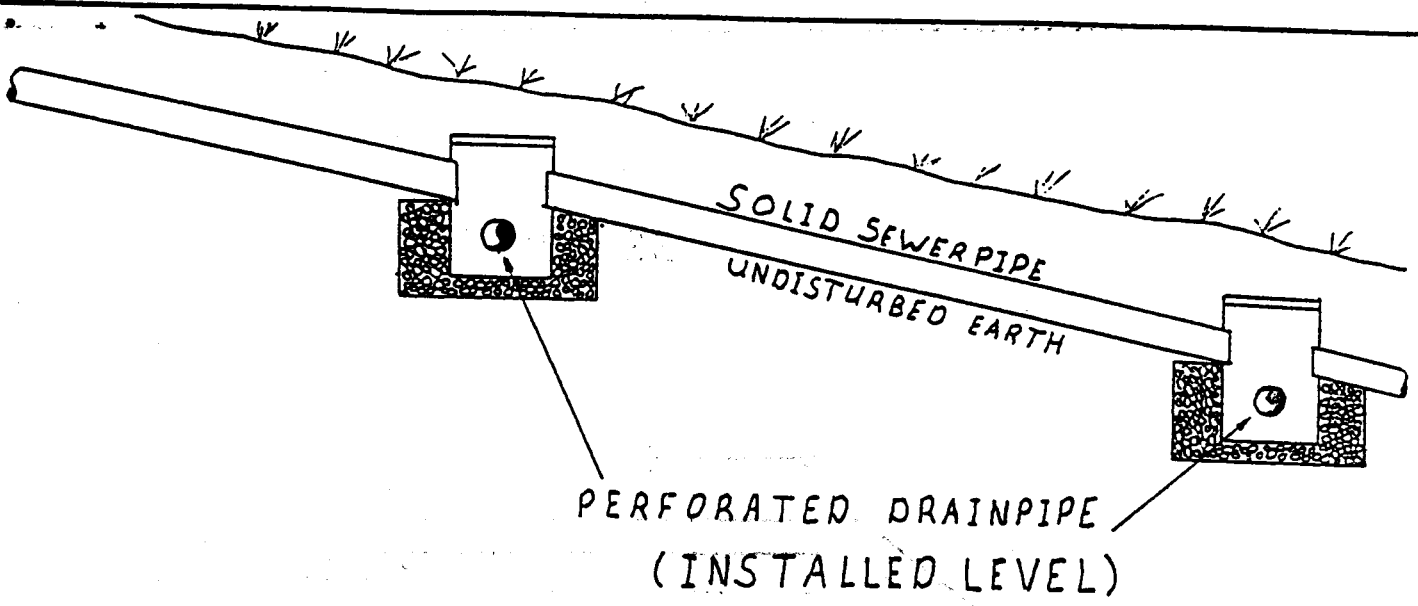

ABSORPTION SYSTEM
USING DROP BOXES

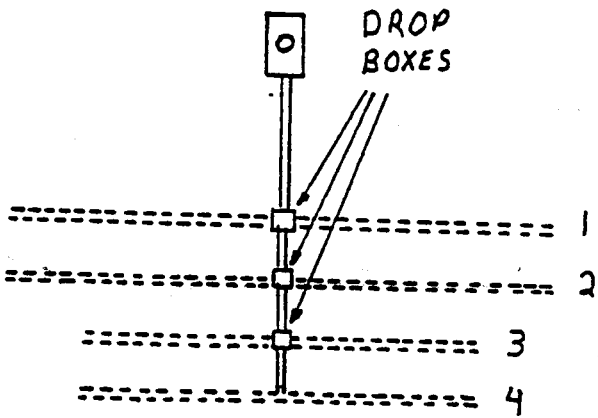

NOTES:

- 1) LEVEL 1+2 MUST EACH CONTAIN A MINIMUM OF 30% OF TOTAL FIELD
- 2) ABSORPTION SYSTEMS USING DROP BOXES SHALL HAVE NO MORE THAN 4 LEVELS

DROP BOXES

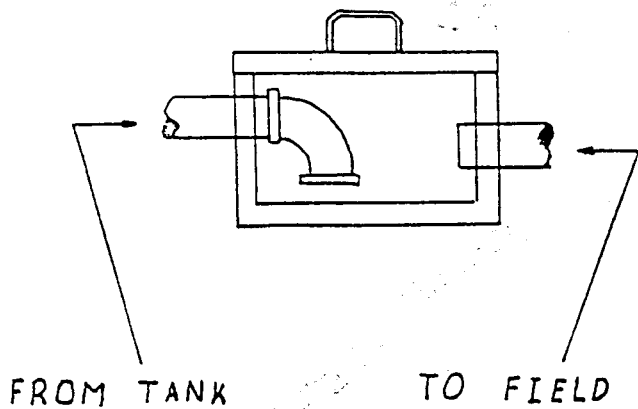

DISTRIBUTION BOXES
MAY BE USED ON LEVEL OR
SLOPED SITES AND ARE
PREFERRED FOR DOSED
SYSTEMS

OUTLETS SHALL DISTRIBUTE
EFFLUENT EQUALLY

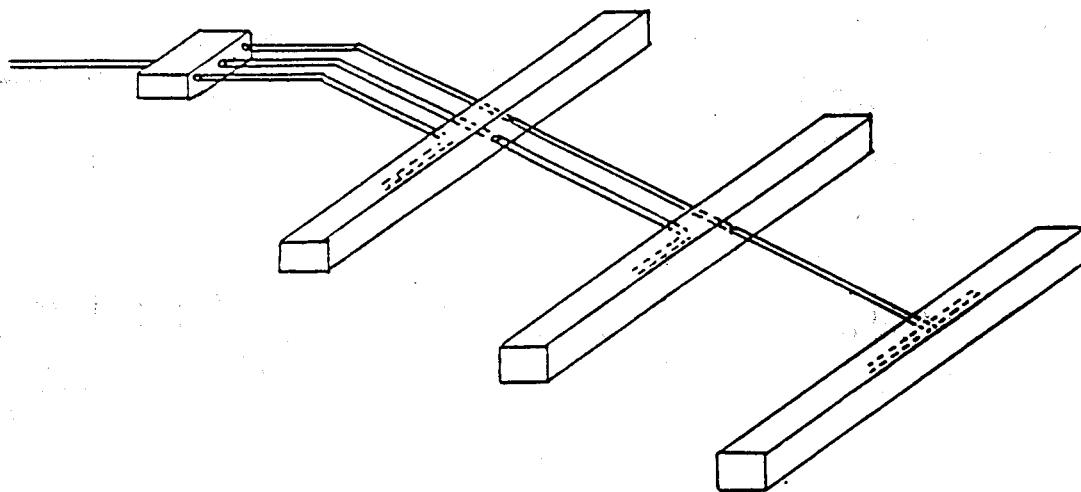

DISTRIBUTION BOX

LAKE

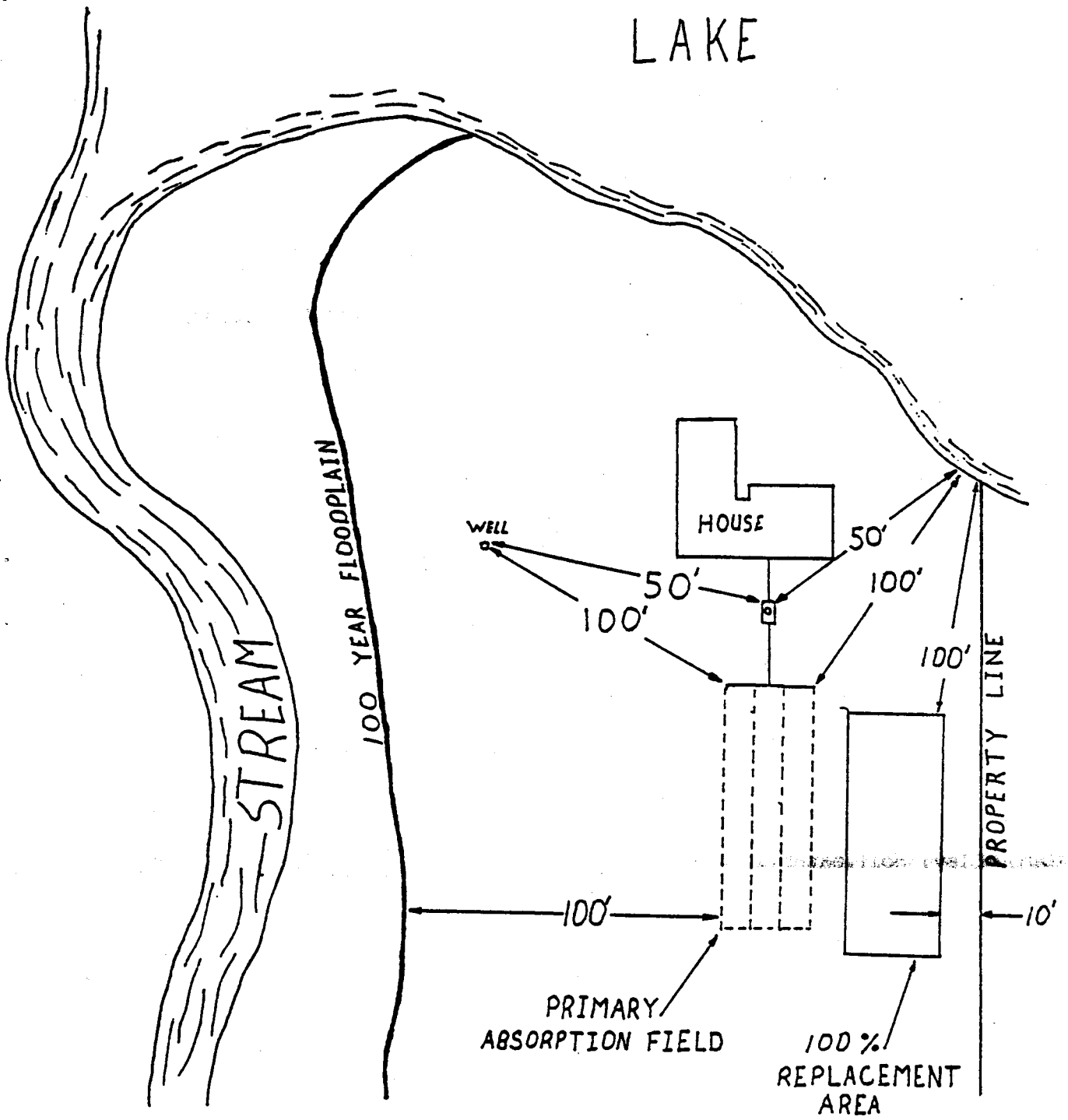

SETBACK DISTANCES

APPENDIX E
Soil Description

- Sands:** Soil material that contains 85% or more of sand; percentage of silt plus one and one-half times the percentage of clay shall not exceed 15%.
- Loamy Sands:** Soil material that contains at the upper limit 85% to 90% sand; percentage of silt, plus one and one-half times the percentage of clay is not less than 15%. At the lower limit, it contains not less than 70% to 85% sand; percentage of silt plus the percentage of clay does not exceed 30%.
- Sandy Loams:** Soil material that contains 20% clay or less (and the percentage of silt plus twice the percentage of clay exceeds 30%) and 52% or more sand; (or) less than 7% clay, less than 50% silt and between 43% and 52% sand.
- Loam:** Soil material that contains 7% to 27% clay, 28% to 50% silt, and less than 52% sand.
- Silt Loam:** Soil material that contains 50% or more silt and 12% to 27% clay (or) 50% to 80% silt and less than 12% clay.
- Silt:** Soil material that contains 80% or more silt and less than 12% clay.
- Sandy clay loam:** Soil material that contains 20% to 35% clay, less than 28% silt, and 45% or more sand.
- Clay Loam:** Soil material that contains 27% to 40% clay and 20% to 45% sand.
- Silty Clay Loam:** Soil material that contains 27% to 40% clay and less than 20% sand.
- Sandy Clay:** Soil material that contains 35% or more clay and 45% or more sand.
- Silty Clay:** Soil material that contains 40% or more clay and 40% or more silt.
- Clay:** Soil material that contains 40% or more clay, less than 45% sand, and less than 40% silt.

APPENDIX E
continued

Estimating
Soil Type

Place approximately 25 g soil in palm. Add water dropwise and knead the soil to break down all aggregates. Soil is at the proper consistency when plastic and moldable, like moist putty.

Add dry soil to soak up water

Does soil remain in a ball when squeezed?

Is soil too dry?

Is soil too wet?

SAND

Place ball of soil between thumb and forefinger gently pushing the soil with the thumb, squeezing it upward into a ribbon. Form a ribbon of uniform thickness and width. Allow the ribbon to emerge and extend over the forefinger, breaking from its own weight.

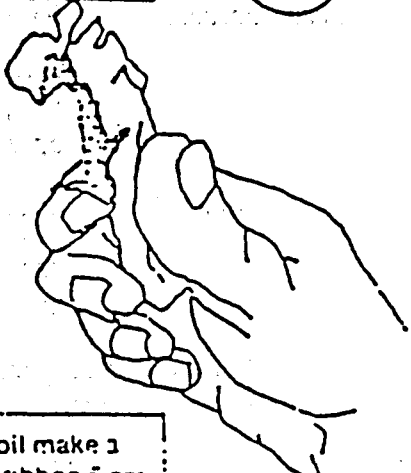

LOAMY SAND

Does soil form a ribbon?

Does soil make a weak ribbon less than 2.5 cm long before breaking?

Does soil make a medium ribbon 2.5-5 cm long before breaking?

Does soil make a strong ribbon 5 cm or longer before breaking?

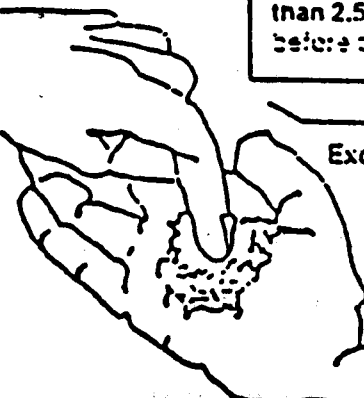

Excessively wet: a small pinch of soil in palm and rub with forefinger

SANDY LOAM

Does soil feel very gritty?

SANDY CLAY LOAM

Does soil feel very gritty?

SANDY CLAY

Does soil feel very gritty?

SILT LOAM

Does soil feel very smooth?

SILTY CLAY LOAM

Does soil feel very smooth?

SILTY CLAY

Does soil feel very smooth?

LOAM

Neither grittiness nor smoothness predominates

CLAY LOAM

Neither grittiness nor smoothness predominates

CLAY

Neither grittiness nor smoothness predominates

Traditional Approaches to Wastewater Systems Design

the sewage flows shown are indeed estimates and therefore do not always agree from table to table. The designer will have to exercise judgment. Local public health or environmental control authorities should be consulted in order to determine if there are mandatory design criteria for the specific location of the planned installation; these criteria, of course, prevail over any estimates presented here.

Table 7. Quantities of Sewage Flows.
(Gallons per person per day — unless otherwise noted)

Type of Establishment	Quantity
Airports (per passenger)	5
Apartments — multiple family (per resident)	60
Bathhouses and swimming pools	10
Camps:	
Campground with central comfort stations	35
With flush toilets, no showers	25
Construction camps (semi-permanent)	50
Day camps (no meals served)	15
Resort camps (night and day) with limited plumbing	50
Luxury camps	100
Cottages and small dwellings with seasonal occupancy	50
Country clubs (per resident member)	100
Country clubs (per non-resident member present)	25
Dwellings:	
Boarding houses	50
additional for non-resident boarders	10
Luxury residences and estates	150
Multiple family dwellings (apartments)	60
Rooming houses	40
Single family dwellings	75
Factories (gallons per person, per shift, exclusive of industrial wastes)	35
Hospitals (per bed space)	250+
Hotels with private baths (2 persons per room)	60
Hotels without private baths	50
Institutions other than hospitals (per bed space)	125
Laundries, self-service (gallons per wash, i.e., per customer)	50
Mobile home parks (per space)	250
Motels with bath, toilet, and kitchen wastes (per bed space)	50
Motels (per bed space)	40
Picnic Parks (toilet wastes only) (per picnicker)	5
Picnic Parks with bathhouses, shower, and flush toilets	10
Restaurants (toilet and kitchen wastes per patron)	10
Restaurants (kitchen wastes per meal served)	3

Traditional Approaches to Wastewater Systems Design

Table 8. Concluded.

Type of Establishment	Estimated Flow Rate (Gallons per day)
Vending Machine Restaurants	*70 per seat at 200 ppm BOD
Hospitals (no resident personnel)	*200 per bed
Institutions (resident)	*100 per person
Laundries (coin-operated)	*400 per machine plus 12-hour cooling tank
Motels	100 per unit
Nursing and Rest Homes	*100 per person
Office Buildings	20 per employee
Schools — Elementary	*15 per pupil
Schools — High and Junior High	*20 per pupil
Service Stations	1000 first bay 500 each additional bay
Shopping Centers (without food service or laundries)	0.1 per square foot of floor space
Subdivisions	400 per home
Swimming Pool (average)	3-5 per swimmer (design load)
With hot water shower	5-7 per swimmer (design load)
Trailer Parks (without service building)	150 per trailer space
(With service building)	175 per trailer space
Vacation Cottages	50 per camper
Youth and Recreation Camps	50 per camper

*Includes food service waste.

**Aeration tanks for these require 48-hour detention period.

†Flow rates are average rates established by many of the state health departments throughout the United States. Please consult the District Sanitary Engineer in your area for any state or local individual design requirements.

Courtesy Pollution Control, Inc.

Table 9. Package Treatment Plant Sizing Data.

Type of Facility	Flow Rate (GPCD)	#5 Day B.O.D. (lbs./capita / day)	Runoff hours	Shock Load Factor
Airports — (per passenger)	5	.020	16	low
Airports — (per employee)	15	.050	16	low
Apartments — Multiple family	75	.175	16	med.
Boarding Houses	50	.140	16	med.
Bowling Alleys — per lane (no food)	75	.150	8	med.
Campgrounds — per tent or travel trailer site — central bathhouse	50	.130	16	med.
Camps — Construction — (semi- permanent)	50	.140	16	med.

Traditional Approaches to Wastewater Systems Design

Table 7. Concluded.
(Gallons per person per day — unless otherwise noted)

Type of Establishment	
Restaurants additional for bars and cocktail lounges	2
Schools:	
Boarding	100
Day, without gyms, cafeterias, or showers	15
Day, with gyms, cafeterias, and showers	25
Day, with cafeterias, but without gyms, or showers	20
Service stations (per vehicle served)	10
Swimming pools and bathhouses	10
Theaters:	
Movie (per auditorium seat)	5
Drive-in (per car space)	5
Travel trailer parks without individual water and sewer hook-ups (per space)	50
Travel trailer parks with individual water and sewer hook-ups (per space)	100
Workers:	
Construction (of semi-permanent camps)	50
Day, at schools and offices (per shift)	15

Source: *Manual of Septic Tank Practice*, DHEW Pub. No. (HSM) 72-10020 (Formerly PHS Pub. No. Rev. 1967, pp. 43-44.

Table 8. Sewage Flow Rate Estimating Guide.†

Type of Establishment	Estimated Flow Rate (Gallons per day)
Apartments	250 one bedroom 300 two bedroom 350 three bedroom
Assembly Halls	2 per seat
Bowling Alleys (no food service)	75 per lane
Churches (small)	3-5 per sanctuary seat
Churches (large, with kitchen)	5-7 per sanctuary seat
Country Clubs	50 per member
Dance Halls	2 per person
Drive-In Theaters	5 per car space
Factories (no showers)	25 per employee
Factories (with showers)	35 per employee
Food Service Operations	
Ordinary Restaurant (not 24-hour)	**35 per seat at 400 ppm BOD
24-hour Restaurant	**50 per seat at 400 ppm BOD
Restaurant along Freeway (24-hour)	**70 per seat at 400 ppm BOD
Tavern (very little food service)	**20 per seat at 400 pm BOD
Curb Service (drive-in)	**50 per car space at 400 ppm BOD

TABLE IX
 RYON'S CORRECTED CRITERIA,
 MAXIMUM WASTEWATER LOADING RATES
 OF DISPOSAL FIELDS

Percolation Rate min./in.	Maximum Loading Rate gal./sq.ft.*/day
1 or less	2.5
2	2.0
3	1.6
4	1.56
5	1.37
10	1.0
20	0.56
30	0.48
40	0.42
60	0.36

*Active infiltration surfaces are
 sidewalls of disposal fields.

FILE 101-B

080593 *SM*

ORDINANCE 1-95

MADISON COUNTY BOARD OF
COUNTY COMMISSIONERS

AN ORDINANCE ADOPTING AND CONFIRMING
SEPTIC SYSTEM REGULATIONS FOR
MADISON COUNTY AND IMPOSING FEES

RECORDER'S OFFICE
Madison County, Montana } ss.

Filed APRIL 5th 19 95

at 4:00 o'clock P.M.

PEGGY KAATZ

Peggy Kaatz County Recorder
Deputy

Fee \$ NONE